

Invacare® TDX SP2® Series



en **Power Wheelchair**
User Manual



This manual **MUST** be given to the user of the product.
BEFORE using this product, read this manual and save for future reference.



Yes, you can.®

© 2015 Invacare® Corporation

All rights reserved. Republication, duplication or modification in whole or in part is prohibited without prior written permission from Invacare. Trademarks are identified by ™ and ®. All trademarks are owned by or licensed to Invacare Corporation or its subsidiaries unless otherwise noted.

Contents

I General	6
1.1 Introduction	6
1.2 Symbols in this manual	6
1.3 Type classification	6
1.4 Intended use	7
1.5 Regulations	7
1.6 Indications	7
1.7 Usability	7
1.8 Warranty	8
1.9 Service life	8
2 Safety	9
2.1 General safety notes	9
2.2 Safety information on the electrical system	11
2.3 Safety information on electromagnetic interference	12
2.4 Safety information on driving and freewheel mode	13
2.5 Safety information with regard to care and maintenance	15
2.6 Safety information regarding changes and modifications to the mobility device	16
2.7 Safety information on wheelchairs with a lifter	17
2.8 Labels on product	18
3 Components	22
3.1 Main parts of the wheelchair	22
3.2 Remotes	22
3.3 The Lifter	22
4 Accessories	24
4.1 Postural belts	24
4.1.1 Types of postural belts	24
4.1.2 Adjusting the postural belt correctly	24

4.2 Using the cane holder	25
4.3 Using the KLICKfix adapter	25

5 Adjusting the mobility device to the user's seating posture	27
5.1 General information on adjusting the mobility device to the user's seating posture	27
5.2 Adjustment possibility for remote	28
5.2.1 Adjusting the remote for the length of the user's arm	29
5.2.2 Adjusting the height of the remote (only for swing-away remote supports)	29
5.2.3 Swivelling the remote to the side	29
5.3 Adjustment options for the Modulite seat unit	29
5.3.1 Adjusting the height of the armrests	29
5.3.2 Adjusting the width of the armrests	30
5.3.3 Adjusting the position of the armrest in depth	30
5.3.4 Adjusting the height (flip-up armrest)	31
5.3.5 Adjusting the height (following armrest)	31
5.3.6 Changing the resistance (flip-up/following armrest)	31
5.3.7 Adjusting the arm pad angle (flip-up/following armrest)	32
5.3.8 Adjusting the position of the arm pad of the flip-up armrest	32
5.3.9 The hip support	33
5.3.10 Adjusting the seat width	36
5.3.11 Adjusting the seat depth (Modulite seat unit)	36
5.4 Adjustment options for Max seat	38
5.4.1 Changing the armrest position	38
5.4.2 Setting the height of the armrests	38
5.4.3 Adjusting the width of the armrests	38
5.4.4 Adjusting the seat depth	39
5.5 Adjusting the seat angle	40
5.5.1 Electrical	40

5.5.2	Manual	40	5.11.3	Setting the end stop of the footrest	53
5.6	Adjusting the backrest	40	5.11.4	Adjusting the length of the legrest	55
5.6.1	Adjusting the height of the backrest (Modulite seat unit)	40	5.12	Vari-A legrests	55
5.6.2	Adjusting the width of the backrest (Modulite seat unit)	41	5.12.1	Swivelling the footrest/legrest outward and/or removing	55
5.6.3	Adjusting the backrest angle (Modulite seat unit)	42	5.12.2	Setting the angle	55
5.6.4	Adjusting the backrest angle (Max seat)	43	5.12.3	Setting the end stop of the legrest	56
5.6.5	Adjusting the tension adjustable backrest upholstery	44	5.12.4	Adjusting the length of the legrest	59
5.6.6	Adjusting the backrest bend	44	5.12.5	Adjusting the depth of the calf pad	59
5.7	Adjusting the headrest	47	5.12.6	Adjusting the height of the calf pad	59
5.7.1	Adjusting the position of the headrest or neckrest	47	5.12.7	Unlocking and swivelling the calf pad backward when alighting	60
5.7.2	Adjusting the height of the headrest or neckrest	47	5.12.8	Adjusting the angle-adjustable foot plate	60
5.7.3	Adjusting the cheek supports	48	5.12.9	Adjusting the angle- and depth-adjustable foot plate	61
5.8	Adjusting the trunk supports	48	5.13	ADM legrests	61
5.8.1	Adjusting the width	48	5.13.1	Swivelling the footrest/legrest outward and/or removing	61
5.8.2	Adjusting the height	48	5.13.2	Setting the angle	61
5.8.3	Adjusting the depth	49	5.13.3	Adjusting the length of the legrest	62
5.9	Adjusting and removing the tray	49	5.13.4	Adjusting the depth of the calf pad	63
5.9.1	Laterally adjusting the tray	49	5.13.5	Adjusting the height of the calf pad	63
5.9.2	Adjusting the depth of the tray / removing the tray	49	5.13.6	Unlocking and swivelling the calf pad backward when alighting	64
5.9.3	Swinging the tray away to the side	50	5.13.7	Adjusting the angle-adjustable foot plate	64
5.10	Center-mounted legrests — manually adjustable	50	5.13.8	Adjusting the angle- and depth-adjustable foot plate	65
5.10.1	Removing the leg rest	50	5.14	Powered elevating legrests (ADE legrests)	65
5.10.2	Setting the angle of the leg rest	50	5.14.1	Swivelling the legrest outward and/or removing	65
5.10.3	Setting the length of the leg rest	51	5.14.2	Setting the angle	65
5.10.4	Setting the angle of the footplate	51	5.14.3	Adjusting the length of the legrest	66
5.10.5	Setting the angle and height of the calf pad	51	5.14.4	Adjusting the depth of the calf pad	66
5.11	Vari-F footrest	52	5.14.5	Adjusting the height of the calf pad	67
5.11.1	Swivelling the footrest/legrest outward and/or removing	52			
5.11.2	Setting the angle	52			

5.14.6	Unlocking and swivelling the calf pad backward when alighting.	67	7.2.4	How to disconnect the mobility device after charging	77
5.14.7	Adjusting the angle-adjustable foot plate	67	7.2.5	Storage and Maintenance.	77
5.14.8	Adjusting the angle- and depth-adjustable foot plate.	68	7.2.6	Instructions on using the batteries	78
5.15	Legrests for Max seat.	68	7.2.7	Transporting batteries.	78
5.15.1	Adjusting the height of the calf pad.	68	7.2.8	General instructions on handling the batteries	79
5.15.2	Adjusting the calf pad width.	69	7.2.9	How to handle damaged batteries correctly	79
5.15.3	Adjusting the length of the legrest	69	7.2.10	Removing the batteries	79
5.16	Adjusting the width of side-mounted legrests.	70	8 Transport	83	
6 Usage	71		8.1	Transport — General information	83
6.1	Driving	71	8.2	Transferring the mobility device to a vehicle	83
6.2	Before driving for the first time.	71	8.3	Use of the mobility device as a seat in a vehicle	84
6.3	Parking and stationary	71	8.3.1	How the mobility device is anchored in a vehicle	86
6.4	Getting in and out of the mobility device.	71	8.3.2	How the user is secured within the wheelchair.	86
6.4.1	Removing the standard armrest in order to side transfer	72	8.4	Transporting the mobility device without occupant	87
6.4.2	Information about getting in and out	72	9 Maintenance	89	
6.5	Taking Obstacles	72	9.1	Maintenance introduction.	89
6.5.1	The "SureStep" System	72	9.2	Cleaning the mobility device.	89
6.5.2	Maximum obstacle height	73	9.3	Inspection checks.	89
6.5.3	Safety information when taking obstacles	73	9.3.1	Before each use of the mobility device	89
6.5.4	The correct way to overcome obstacles.	73	9.3.2	Weekly	90
6.6	Driving up and down gradients	74	9.3.3	Monthly	90
6.7	Use on public roads.	74	9.3.4	Inspections performed	90
6.8	Pushing the mobility device in freewheel mode	75	9.4	Short-term storage	92
6.8.1	Disengaging motors	75	9.5	Long-term storage.	92
7 Electrical system.	76		9.6	Repair Instructions.	93
7.1	Electronics protection system.	76	9.6.1	Repairing tire punctures (wheel rim type 3.00-8")	93
7.2	Batteries	76	10 After Use	95	
7.2.1	General information on charging	76	10.1	Reconditioning.	95
7.2.2	General instructions on charging	76	10.2	Disposal	95
7.2.3	How to charge the batteries	77	11 Technical data.	96	
			11.1	Technical specifications.	96

I General

I.1 Introduction

Thank you for choosing an Invacare product.

This user manual contains important information about the handling of the product. In order to ensure safety when using the product, read the user manual carefully and follow the safety instructions.

Please note that there may be sections in this user manual, which are not relevant to your product, since this manual applies to all existing modules (on the date of printing).

If you find that the font size in the print version of the user manual is difficult to read, you can download it as a pdf from the Invacare website (see back page of this manual). The pdf can then be scaled on screen to a font size that is more comfortable for you.

This mobility device has been constructed for a large circle of users with different requirements.

The decision whether the model is suitable for the user may only be taken by medical specialists with appropriate expertise.

Invacare or their statutory representatives can accept no liability in cases in which the mobility device has not been adapted to suit the users' handicaps.

Some maintenance and settings can be performed by the user or his/hers attendants. Certain adjustments do however require technical training and may only be carried out by your Invacare specialist dealer. Refer to the Inspection checks chapter in 9 Maintenance, page 89. Damages and errors caused by nonobservance of the user manual or as a result of incorrect maintenance are excluded from all guarantees.

I.2 Symbols in this manual

In this manual warnings are indicated by symbols. The warning symbols are accompanied by a heading that indicates the severity of the danger.



WARNING

Indicates a hazardous situation that could result in serious injury or death if it is not avoided.



CAUTION

Indicates a hazardous situation that could result in minor or slight injury if it is not avoided.



IMPORTANT

Indicates a hazardous situation that could result in damage to property if it is not avoided.



Gives useful tips, recommendations and information for efficient, trouble-free use.



This product complies with Directive 93/42/EEC concerning medical devices. The launch date of this product is stated in the CE declaration of conformity.

Tools:



This symbol identifies a list of various tools, components and items which you will need in order to carry out certain work. Please do not attempt to carry out the work if you do not have the listed tools available.

I.3 Type classification

This vehicle has been classified according to EN 12184 as a **class B mobility product** (for indoor and outdoor areas). It is therefore

compact and agile enough for indoor areas, but also able to overcome many obstacles in outdoor areas.

1.4 Intended use

This mobility device was designed for persons whose ability to walk is impaired, but who are still in terms of their eyesight and physically and mentally able to operate an electric mobility device.

1.5 Regulations

The vehicle was successfully tested according to German and international standards as to its safety. It satisfies the requirements according to RoHS 2011/65/EU, REACH 1907/2006/EC and DIN EN 12184 including EN 1021-2 and ISO 7176-14. It was also tested successfully according to EN 60529 IPX4 as to its resistance to spray water, and is therefore well suited for weather conditions such as typical European weather conditions. When equipped with an appropriate lighting system, the vehicle is suitable for use on public roads.

1.6 Indications

The use of this power wheelchair is recommended for the following indications:

- The inability or a greatly restricted ability to walk within the scope of the basic requirement to be able to move within one's own four walls.
- The need to leave the dwelling place in order to get some fresh air during a short walk or to reach those places generally to be found at close distance to the dwelling and where everyday business is carried out.

Provision of power wheelchairs for interior and exterior areas is advisable if the use of hand-operated wheelchairs is no longer possible on account of the disability, yet proper operation of an electromotive drive unit is still practicable.

1578997-C

1.7 Usability

Only use a mobility device when it is in perfect working order. Otherwise, you might put yourself and others at risk.

The following list does not claim to be exhaustive. It is only intended to show some of the situations that could affect the usability of your mobility device.

In certain situations, you should immediately stop using your mobility device. Other situations allow you to use the mobility device to get to your dealer.

You should immediately stop using your mobility device if its usability is restricted due to:

- brake failure

You should immediately contact an authorized Invacare dealer if the usability of your mobility device is restricted due to:

- the lighting system (if fitted) failing or being defective
- reflectors falling off
- worn thread or insufficient tire pressure
- damage to the armrests (e.g. torn armrest padding)
- damage to the legrest hangers (e.g. missing or torn heel straps)
- damage to the postural belt
- damage to the joystick (joystick cannot be moved into the neutral position)
- cables that are damaged, kinked, pinched or have come loose from the fixation
- the mobility device drifting when braking
- the mobility device pulling to one side when moving
- unusual sounds developing or occurring

Or if you have the feeling that something is wrong with your mobility device.

1.8 Warranty

The terms and conditions of the warranty are part of the general terms and conditions particular to the individual countries in which this product is sold.

1.9 Service life

We estimate a service life of five years for this product, provided it is used in strict accordance with the intended use as set out in this document and all maintenance and service requirements are met.

The estimated service life can be exceeded if the product is carefully used and properly maintained, and provided technical and scientific advances do not result in technical limitations. The service life can also be considerably reduced by extreme or incorrect usage. The fact that we estimate a service life for this product does not constitute an additional warranty.

2 Safety

2.1 General safety notes

**WARNING!**

Risk of injury if mobility device is used in any other way than the purpose described in this manual

- Only ever use the mobility device in accordance with the instructions in this user manual.
- Pay strict attention to the safety information.

**WARNING!**

Risk of injury if the mobility device is driven when ability to operate a vehicle is impaired by medication or alcohol

- Never drive the mobility device under the influence of medication or alcohol. If necessary, the mobility device must be operated by an attendant who is physically and mentally able.

**WARNING!**

Risk of damage or injury if mobility device is accidentally set into motion

- Switch the mobility device off before you get in, get out or handle unwieldy objects.
- When the drive is disengaged, the brake inside the drive is deactivated. For this reason, pushing the mobility device by an attendant is only recommended on flat surfaces, never on gradients. Never leave your mobility device on a gradient with its motors disengaged. Always re-engage the motors immediately after pushing the mobility device (refer to Pushing the mobility device in freewheel mode).

**WARNING!**

Risk of injury if the mobility device is switched off while driving, for example by pressing the On/Off Button or disconnecting a cable, due to it coming to an abrupt, sharp stop

- If you have to brake in an emergency, simply release the joystick which will bring you to a halt (refer to the remote user manual for more information).



WARNING!

Risk of injury when transferring mobility device to a vehicle for transport with the occupant seated in it

- It is always better to transfer the mobility device to a vehicle without the occupant seated in it.
- If the mobility device needs to be loaded up a ramp together with its driver, ensure that the ramp does not exceed the maximum safe slope (refer to 11 Technical data, page 96).
- If the mobility device does need to be loaded using a ramp which exceeds the maximum safe slope (refer to 11 Technical data, page 96), then you must use a winch. An attendant can safely monitor and assist the loading process.
- As an alternative you can use a platform lift. Ensure that the total weight of the mobility device including the user does not exceed the maximum permissible weight for the platform lift or winch if you are using.



WARNING!

Risk of falling out of the mobility device

- Do not slide forward on the seat, do not lean forward between your knees, do not lean backwards out over the top of the backrest, for example to reach an object.
- If a posture belt is installed, it should be correctly adjusted and used each time you use the mobility device.
- When transferring to a different seat, position the mobility device as close as possible to the new seat.



CAUTION!

Risk of injury if maximum permissible load is exceeded

- Do not exceed the maximum permissible load (refer to 11 Technical data, page 96).
- The mobility device is only designed for use by a single occupant whose maximum weight does not exceed the maximum permissible load of the device. Never use the mobility device to transport more than one person.



CAUTION!

Risk of injury due to wrong lifting or dropping of heavy components

- When maintaining, servicing or lifting any part of your mobility device, take into account the weight of the individual components especially the batteries. Be sure at all times to adopt the correct lifting posture and ask for assistance if necessary.



CAUTION!

Risk of injury by moving parts

- Make sure that no injury is incurred by moving parts of the mobility device, like wheels or one of the lifter modules (if fitted), especially when children are around.



CAUTION!

Risk of injury from hot surfaces

- Do not leave the mobility device in direct sunlight for prolonged periods. Metal parts and surfaces such as the seat and armrests can become very hot.

**CAUTION!****Risk of fire or breaking down due to electric devices being connected**

- Do not connect any electric devices to your mobility device that are not expressly certified by Invacare for this purpose. Have all electrical installations done by your authorized Invacare dealer.

2.2 Safety information on the electrical system**DANGER!****Risk of death, serious injury or damage**

Misuse of the mobility device may cause the mobility device to start smoking, sparking, or burning. Death, serious injury, or damage may occur due to fire.

- DO NOT use the mobility device other than its intended purpose.
- If the mobility device starts smoking, sparking, or burning, discontinue using the mobility device and seek service IMMEDIATELY.

**DANGER!****Risk of fire**

Switched on lamps produce heat. If you cover the lamps with fabrics such as clothes, there is a risk that the fabric may catch fire.

- NEVER cover the light system with fabric.

**DANGER!****Risk of death, serious injury or damage when carrying along oxygen systems**

Textiles and other materials that normally would not burn are easily ignited and burn with great intensity in oxygen enriched air.

- Check the oxygen tubing daily, from the cylinder to the delivery site, for leaks and hold away from electrical sparks and any source of ignition.

**WARNING!****Risk of injury or damage due to electrical shorts**

Connector pins on cables connected to the power module can still be live even when the system is off.

- Cables with live pins should be connected, restrained or covered (with non-conductive materials) so that they are not exposed to human contact or materials that could cause electrical shorts.
- If cables with live pins have to be disconnected, for example, when removing the bus cable from the remote for safety reasons, make sure to restrain or cover the pins (with non-conductive materials).



DANGER!

Risk of death, serious injury, or damage

Corroded electrical components due to water or liquid exposure can result in death, serious injury, or damage.

- Minimize exposure of electrical components to water and/or liquids.
- Electrical components damaged by corrosion **MUST** be replaced immediately.
- Mobility devices that are frequently exposed to water/liquids may require replacement of electrical components more frequently.



DANGER!

Risk of death or serious injury

Failure to observe these warnings can cause an electrical short resulting in death, serious injury, or damage to the electrical system.

- The **POSITIVE (+) RED** battery cable **MUST** connect to the **POSITIVE (+) battery terminal(s)/post(s)**. The **NEGATIVE (-) BLACK** battery cable **MUST** connect to the **NEGATIVE (-) battery terminal(s)/post(s)**.
- **NEVER** allow any of your tools and/or battery cable(s) to contact **BOTH** battery post(s) at the same time. An electrical short may occur and serious injury or damage may occur.
- Install protective caps on positive and negative battery terminals.
- Replace cable(s) immediately if cable(s) insulation becomes damaged.
- **DO NOT** remove fuse or mounting hardware from **POSITIVE (+) red** battery cable mounting screw.



DANGER!

Risk of death or serious injury

Electric shock can cause death or serious injury

- To avoid electric shock, inspect plug and cord for cuts and/or frayed wires. Replace cut cords or frayed wires immediately.



Risk of damage to the mobility device

A failure in the electric system can lead to unusual behavior such as continuous light, no light, or noises from the magnetic brakes.

- If a failure exists, switch off the remote and switch it on again.
- If a failure still exists, then disconnect or remove the power source. Depending on the mobility device model, you can either remove the battery packs or disconnect the batteries from the power module. If in doubt which cable to disconnect, contact your dealer.
- In any case, contact your dealer.

2.3 Safety information on electromagnetic interference

This electric vehicle was successfully tested in accordance with International standards as to its compliance with Electromagnetic Interference (EMI) regulations. However, electromagnetic fields, such as those generated by radio and television transmitters, and cellular phones can influence the functions of electric vehicles. Also, the electronics used in our vehicles can generate a low level of electromagnetic interference, which however will remain within the tolerance permitted by law. For these reasons we ask you to please observe the following precautions:

**WARNING!****Risk of malfunction due to electromagnetic interference**

- Do not switch on or operate portable transceivers or communication devices (such as radio transceivers or cellular phones) when the vehicle is switched on.
- Avoid getting near strong radio and television transmitters.
- In case the vehicle should be set in motion unintentionally or the brakes are released, switch it off immediately.
- Adding electrical accessories and other components or modifying the vehicle in any way can make it susceptible to electromagnetic interference. Keep in mind that there is no sure way to determine the effect such modifications will have on the overall immunity of the electronic system.
- Report all occurrences of unintentional movement of the vehicle, or release of the electric brakes to the manufacturer.

2.4 Safety information on driving and freewheel mode

**DANGER!****Risk of death, serious injury, or damage**

- Malfunctioning joystick could cause unintended/erratic movement resulting in death, serious injury, or damage
- If unintended/erratic movement occurs, stop using the wheelchair immediately and contact a qualified technician.

**WARNING!****Risk of injury if the mobility device tips over**

- Inclines and declines can only be travelled up to the maximum safe slope (refer to II Technical data, page 96).
- Always return the backrest of your seat or the seat tilt to an upright position before ascending slopes. We recommend that you position the seat backrest and the seat tilt (if fitted) slightly to the rear before descending slopes.
- Only ever drive downhill at a maximum of 2/3 of the top speed. Avoid abrupt braking or accelerating on gradients.
- If at all possible, avoid driving on wet, slippery, icy, or oily surfaces (such as snow, gravel, ice etc.) where there is a risk of you losing control over the vehicle, especially on a gradient. This may include certain painted or otherwise treated wood surfaces. If driving on such a surface is inevitable, then always drive slowly and with the utmost caution.
- Never attempt to overcome an obstacle when on an uphill or downhill gradient.
- Never attempt to drive up or down a flight of steps with your mobility device.
- When overcoming obstacles, always observe the maximum obstacle height (refer to II Technical data, page 96 and information about overcoming obstacles in 6.5 Taking Obstacles, page 72).
- Avoid shifting your center of gravity as well as abrupt joystick movements and changes of direction when the mobility device is in motion.



WARNING!

Risk of injury if the mobility device tips over (continued)

- Never use the mobility device to transport more than one person.
- Do not exceed the overall maximum permissible load or the maximum load per axle (refer to II Technical data, page 96).
- Note that the mobility device will brake or accelerate if you change the driving mode whilst the mobility device is in motion.



WARNING!

Risk of serious injury or damage

Improper positioning while leaning or bending could cause the wheelchair to tip forward resulting in serious injury or damage

- To assure stability and proper operation of your mobility device, you must at all times maintain proper balance. Your power wheelchair has been designed to remain upright and stable during normal daily activities as long as you DO NOT move beyond the center of gravity.
- DO NOT lean forward out of the mobility device any further than the length of the armrests.
- DO NOT attempt to reach objects if you have to move forward in the seat or pick them up from the floor by reaching down between your knees.



WARNING!

Risk of breaking down in adverse weather conditions, i.e. extreme cold, in an isolated area

- If you are a user with severely limited mobility, we advise that in the case of adverse weather conditions DO NOT attempt a journey without an accompanying attendant.



WARNING!

Risk of injury if your foot slides off the footrest and gets caught underneath the mobility device when it is in motion

- Make sure each time before you drive the mobility device that your feet are squarely and securely in place on the footplates, and that both legrests are properly locked into place.



WARNING!

Risk of injury if you collide with an obstacle when driving through narrow passages such as doorways and entrances

- Drive through narrow passages in the lowest driving mode and with due caution.

**WARNING!****Risk of injury**

If your mobility device has been fitted with elevating legrests, there is a risk of personal injury and damage to the mobility device if you drive the mobility device with the legrests raised.

- To avoid unwanted displacement of the mobility device center of gravity to the front (especially when travelling downhill) and in order to avoid damage to the mobility device, elevating legrests must always be lowered during normal travelling.

**WARNING!****Tipping hazard if antitippers are removed, damaged or changed to a position different to the factory settings**

- Antitippers should only ever be removed for dismantling the mobility device for transport in a vehicle or for storage.
- The antitippers must always be fitted if the mobility device is being used.

**WARNING!****Risk of tipping**

Antitippers (stabilizers) are only effective on firm ground. They sink in on soft ground such as grass, snow or mud if the mobility device rests itself on them. They lose their effect and the mobility device can tip over.

- Only drive with extreme care on soft ground, especially during uphill and downhill journeys. In the process pay increased attention to the tip stability of the mobility device.

2.5 Safety information with regard to care and maintenance

**DANGER!****Risk of death, serious injury, or damage**

Incorrect repair and/or servicing of this mobility device performed by users/caregivers or unqualified technicians can result in death, serious injury, or damage.

- DO NOT attempt to carry out maintenance work that is not described in this user manual. Such repair and/or service MUST be performed by a qualified technician. Contact a dealer or Invacare technician.

**CAUTION!****Risk of accident and loss of warranty if maintenance is insufficient**

- For reasons of safety and in order to avoid accidents which result from unnoticed wear, it is important that this mobility device undergoes an inspection once every year under normal operating conditions (see inspection plan contained in service instructions).
- Under difficult operating conditions such as daily travel on steep slopes, or in the case of use in medical care cases with frequently changing mobility device users, it would be expedient to carry out intermediate checks on the brakes, accessories and running gear.
- If the mobility device is to be operated on public roads, the vehicle driver is responsible for ensuring that it is in an operationally reliable condition. Inadequate or neglected care and maintenance of the mobility device will result in a limitation of the manufacturer's liability.

2.6 Safety information regarding changes and modifications to the mobility device



DANGER!

Risk of serious injury or damage

Use of incorrect or improper replacement (service) parts may cause injury or damage

- Replacement parts **MUST** match original Invacare parts.
- Always provide the wheelchair serial number to assist in ordering the correct replacement parts.



CAUTION!

Risk of injuries and damage to the mobility device, in case the suspension is adjusted without the immobilization mechanism of the front antitippers being re-adjusted

- When the hardness of the suspension is adjusted, the immobilization mechanism of the front antitippers must without fail be checked and, if necessary, also re-adjusted.



CAUTION!

Risk of injuries and damage to mobility device due to unapproved components and accessory parts

Seating systems, additions and accessory parts which have not been approved by Invacare for use with this mobility device can affect the tipping stability and increase tipping hazards.

- Only ever use seating systems, additions and accessory parts which have been approved by Invacare for this mobility device.

Seating systems which are not approved by Invacare for use with this mobility device do not, under certain circumstances, comply with the valid standards and could increase the flammability and the risk of skin irritation.

- Only use seating systems that have been approved by Invacare for this mobility device.

Electrical and electronic components which have not been approved by Invacare for use with this mobility device can cause fire hazards and lead to electromagnetic damage.

- Only ever use electrical and electronic components which have been approved by Invacare for this mobility device.

Batteries which have not been approved by Invacare for use with this mobility device can cause chemical burns.

- Only ever use batteries which have been approved by Invacare for this mobility device.

**CAUTION!****Risk of injuries, and damage to the mobility device, if unapproved backrests are used**

A retrofitted backrest which is not approved by Invacare for use with this mobility device may overload the backrest tube and thus increase the risk of injuries and of damage to the mobility device.

- Please contact your Invacare specialist dealer who will perform risk analyses, calculations, stability checks etc. to ensure that the backrest can be used safely.

**CE marking of the mobility device**

- The conformity assessment/CE marking was carried out in accordance with Directive 93/42 EEC and only applies to the complete product.
- The CE marking is invalidated if components or accessories are replaced or added that have not been approved for this product by Invacare.
- In this case, the company that adds or replaces the components or accessories is responsible for the conformity assessment/CE marking or for registering the mobility device as a special design and for the relevant documentation.

**Important information about maintenance work tools**

- Some maintenance work which is described in this manual and can be carried out by the user without problems require the correct tools for proper work. If you do not have the correct tool available we do not recommend that you try to carry out the relevant work. In this case, we urgently recommend that you contact an authorized specialist workshop.

2.7 Safety information on wheelchairs with a lifter**WARNING!****Risk of injury by moving parts**

- Never let objects get caught in the space underneath a raised lifter.
- Make sure that neither you nor anyone else is injured by placing hands, feet other body extremities under the raised seat.
- Should you not be able to view under the seat, for example, due to limited manoeuvrability, turn the wheelchair once on its own axle before you lower the seat. This will allow you to make sure that nobody is located in the danger zone.



CAUTION!

Risk of injury if the wheelchair tips over

- Never exceed the maximum permissible load (see chapter 11 Technical data, page 96).
- Avoid dangerous driving situations when the lifter is in a raised position, such as trying to overcome obstacles like kerbs or driving up or down steep gradients.
- Never lean out of the seat when the lifter is raised.
- Inspect the lifter module at least once a month to make sure the automatic speed reduction function, which reduces the speed of the wheelchair when the lifter is raised, is working properly (see chapter 3.3 The Lifter, page 22). Notify your authorised dealership immediately if it is not working properly.



CAUTION!

Risk of malfunction of the lifter module

- Inspect the lifter module at regular intervals to make sure there are no foreign objects or visible damage, and to make sure the electric plugs are firmly inserted into their sockets.



CAUTION!

Damage to wheelchair caused by one-sided loading on lifter pillar

- One-sided loading occurs if the seat is raised and/or tilted. Always return your seat backrest to the upright position and the seat tilting to the horizontal position before ascending slopes. Never subject the lifter pillar to continuous single-sided loading. The raising and tilting function of the seat only provides additional rest positions.











Important information regarding speed reduction with raised lifter

- If the lifter has been raised above a certain point, the drive electronics considerably reduces the speed of the wheelchair. If speed reduction has been activated, drive mode can only be used to carry out minor movements of the wheelchair and not for regular driving. To drive normally, please lower the lifter until the speed reduction has been deactivated again.





2.8 Labels on product







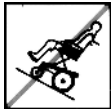

A		<p>If the mobility device is fitted with a tray, it is imperative that it is removed and safely stowed when transporting the mobility device in a vehicle.</p>
B	<p>Identification of the lashing eyes at the front and back:</p>   	<p>This symbol indicates the position of an anchor point when using a lashing system during transport.</p> <p>If the symbol appears on a bright yellow sticker, the anchoring point is suitable for fixation of the mobility device in a vehicle for use as a vehicle seat.</p> <p>Warning that the mobility device may not be used as a vehicle seat</p> <p>This mobility device does not satisfy the requirements of ISO 7176-19.</p>
C		<p>Identification label sticker on the chassis at the right.</p> <p>For details see below.</p>

D		<p>Warning regarding the use of the lifter.</p> <p>For details see below.</p>
E		<p>Indication of the maximum width to which the armrest can be set</p>
F		<p>Identification of the position of the coupling lever for driving and push operation (only the right side visible in the picture).</p> <p>For details see below.</p>
G		<p>This wheelchair may be used as a vehicle seat, but only if it is equipped with a headrest that has been approved by Invacare for this purpose.</p> <ul style="list-style-type: none"> Always make sure that the wheelchair is equipped with a headrest approved by Invacare before using it as a vehicle seat.

Explanation of symbols on labels

	<p>Date of manufacture</p>
	<p>This product complies with Directive 93/42/EEC concerning medical devices. The launch date of this product is stated in the CE declaration of conformity.</p>
	<p>This product has been supplied from an environmentally aware manufacturer. This product may contain substances that could be harmful to the environment if disposed of in places (landfills) that are not appropriate according to legislation.</p> <ul style="list-style-type: none"> • The 'crossed out wheeled bin' symbol is placed on this product to encourage you to recycle wherever possible. • Please be environmentally responsible and recycle this product through your recycling facility at its end of life.
	<p>Do not lean out when the lifter is raised!</p>
	<p>Do not drive up or down slopes when the lifter is raised!</p>

	<p>Do not allow any body parts to get under a raised seat!</p>
	<p>Never drive with two people!</p>
	<p>Never drive over uneven surfaces when the lifter is raised!</p>
	<p>This symbol indicates the “Drive” position of the coupling lever. In this position the motor is engaged and the motor brakes are operational. You can drive the mobility device.</p> <ul style="list-style-type: none"> • Note that for driving purposes both motors must always be engaged.

	<p>This symbol indicates the “Push” position of the coupling lever. In this position the motor is disengaged and the motor brakes are not operational. The mobility device can be pushed by an attendant and the wheels turn freely.</p> <ul style="list-style-type: none">• Note that the remote must be switched off.• Also note the information provided in section 6.8 Pushing the mobility device in freewheel mode, page 75.
	<p>Read the user manual</p>

3 Components

3.1 Main parts of the wheelchair



- (A) Push handle
- (B) Armrest
- (C) Drive wheel
- (D) Lever for disengaging a motor (only visible on right-hand side of picture)
- (E) Remote

3.2 Remotes

Your mobility device may be fitted with one of several different remotes. For information on the different functions and how to operate a particular remote, refer to its corresponding user manual (enclosed).

3.3 The Lifter

The electric lifter is operated from the remote. Refer to the remote manual for more information.



Information regarding operation of the lifter at temperatures of less than 0 °C

- Invacare mobility aids are fitted with safety mechanisms that prevent capacity overload of the electronic components. At operating temperatures below freezing point this can, in particular, lead to the lifter actuator being shut down after approx. 1 second operating time.
- The lifter can be raised or lowered gradually by repeatedly operating the joystick. In many cases this generates sufficient heat for the actuator to operate as normal.



NOTE - speed limiter

- The lifter is fitted with sensors which reduce the mobility device speed as soon as the lifter is raised above a certain point.
- This takes place to guarantee the tipping stability of the mobility device and to avoid damage to the legrests.
- If the speed limit is activated, a corresponding blink code is displayed on the remote or a reduced drive level is set automatically. Please refer to the remote manual for more information.
- To reapply normal speed, run the lifter down until the status display stops blinking.



CAUTION!

Risk of tipping, if the speed limiter sensors fail when the lifter is raised

- If you find that the speed reduction function is not working when the lifter is raised, do not drive with the lifter raised and immediately contact an authorized Invacare dealer.

4 Accessories

4.1 Postural belts

A postural belt is an option which can either be fixed to the mobility device ex-works or can be retrofitted by your specialist dealer. If your mobility device is fitted with a postural belt, your specialist dealer will have informed you about fitting and usage.

The postural belt is used to help the mobility device user keep an optimum sitting position. Correct use of the belt assists the user in sitting securely, comfortably and well-positioned in the mobility device, especially for such users who do not have such a good sense of balance while sitting.



We recommend using the postural belt whenever the mobility device is used. The belt should be tight enough to ensure that you are sitting comfortably and that your body is in the correct sitting position.

4.1.1 Types of postural belts

Your mobility device can be fitted with the following postural belt types ex-works. If your mobility device has been fitted with a different belt to those listed below, please ensure that you have received the manufacturer's documentation with regard to correct fitting and use.

Belt with metal buckle, adjustable both sides



Belt can be adjusted on both sides. This means that the buckle can be centrally positioned.

Harness with metal buckle, adjustable on both sides

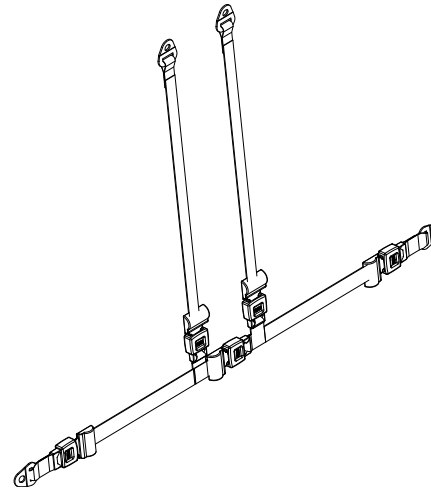

Harness can be adjusted on both sides. This ensures that the buckle is always centrally positioned.

4.1.2 Adjusting the postural belt correctly

1. Ensure that you are sitting correctly, which means that you are sitting right at the back of the seat, your pelvis is positioned erect and as symmetrically as possible, not to the front, to the side or at one edge of the seat.
2. Position the postural belt so that your hipbones can be easily felt above the belt.
3. Adjust the belt length using one of the adjustment aids described above. The belt should be adjusted so that you can fit a flat hand between the belt and your body.

4. The buckle should be positioned as centrally as possible. In doing so, carry out adjustments on both sides as much as possible.
5. Check your belt every week to ensure that it is still in good working condition, to ensure it has no damage or wear, and that it is fixed properly to the mobility device. If the belt is only fastened with a bolted connection, ensure that the connection has not loosened or come undone. You can find more information about maintenance work on belts in the service manual, which is available from Invacare.

4.2 Using the cane holder

If your mobility device is fitted with a cane holder, it can be used for the safe transport of a walking cane, underarm or forearm crutches. The cane holder consists of a plastic container (bottom) and a Velcro fastener (top).



CAUTION!

Risk of injury! A walking cane or crutches that are not secured during transport (on the user's lap, for example) can cause injury to the user or other persons!

- During transport, walking canes or crutches should always be secured using a cane holder!

1. Open the upper Velcro fastener.
2. Place the lower end of the walking cane or the crutches in the container at the bottom.
3. The walking cane or the crutches can be secured at the upper end using the Velcro fastener.

4.3 Using the KLICKfix adapter

Your mobility device can be fitted with the mini-adapter from the Rixen + Kaul KLICKfix system. To this you can attach various

accessories such as the cellphone case supplied by Invacare, which you can use to transport your cellphone, sports glasses etc.



Risk posed by unsecured accessories

Accessories can fall off and get lost if they are not properly secured.

- Check that the accessory is correctly locked in and seated securely every time you use the mobility device.



Risk of breakage due to excessive load

The KLICKfix adapter can break if too great a load is applied.

- The maximum permitted load on the KLICKfix adapter is 1 kg.

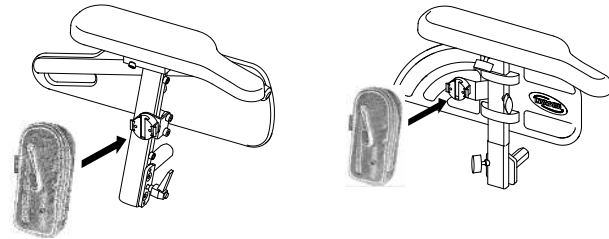

Securing the accessory:

1. Push the accessory into the KLICKfix adapter. The accessory locks in securely.

Removing the accessory:

1. Press the red button and remove the accessory.

The adapter can turn in 90° steps, allowing you to attach an accessory from any of four different directions. Please refer to the installation

Invacare® TDX SP2® Series

instructions which are available from your Invacare dealer or directly from Invacare.

More information on the KCLICKfix system is available at <http://www.klickfix.com>.

5 Adjusting the mobility device to the user's seating posture

5.1 General information on adjusting the mobility device to the user's seating posture



DANGER!

Risk of death, serious injury, or damage

Continued use of the mobility device that is not set to the correct specifications may cause erratic behavior of the mobility device resulting in death, serious injury, or damage.

- Performance adjustments should only be made by professionals of the healthcare field or persons fully conversant with this process and the driver's capabilities.
- After the mobility device has been set-up/adjusted, check to make sure that the mobility device performs to the specifications entered during the set-up procedure. If the mobility device does not perform to specifications, IMMEDIATELY turn the mobility device Off and re-enter set-up specifications. Contact Invacare, if mobility device still does not perform to correct specifications.



DANGER!

Risk of death, serious injury, or damage

Attaching hardware that is loosely secured or missing could cause instability resulting in death, serious personal injury, or property damage.

- After ANY adjustments, repair or service and before use, make sure that all attaching hardware is present and tightened securely.



WARNING!

Risk of injury or damage

Incorrect set up of this mobility device performed by users/caregivers or unqualified technicians can result in injury or damage.

- DO NOT attempt to set up this mobility device. Initial set up of this mobility device MUST be performed by a qualified technician.
- Adjustment by the user is only recommended after they have been given appropriate guidance by the healthcare professional.



CAUTION!

Damage to mobility device and accident hazard

It is possible that collisions can occur between mobility device components due to various combinations of adjustment options and their individual settings

- The mobility device is fitted with an individual, multiply adjustable seating system including adjustable legrests, armrests, a headrest or other options. These adjustment options are described in the following chapters. They are used to adapt the seat to the physical requirements and the condition of the user. When adapting the seating system and the seat functions to the user, ensure that no mobility device components collide.



Electrical adjustment options

- Please refer to the user manual for your remote for more information on operating electrical adjustment options.

5.2 Adjustment possibility for remote

The following information is valid for all seating systems.



CAUTION!

Risk of the remote being pushed backwards during an accidental collision with an obstacle, such as a doorframe or table, and the joystick being jammed against the armpad if the position of the remote is adjusted and all screws are not completely tightened

This will cause the mobility device to drive forward uncontrollably and potentially injure the mobility device user and any person standing in the way.

- When adjusting the position of the remote, always make sure to tighten all screws securely.
- If this should accidentally happen, immediately switch the mobility device electronics OFF at the remote.



CAUTION!

Risk of injury

When leaning on the remote, for example, when transferring into or out of the wheelchair, the remote holder may break and the user may fall out of the chair.

- Never lean on the remote as a support for, for example, transfer.

5.2.1 Adjusting the remote for the length of the user's arm

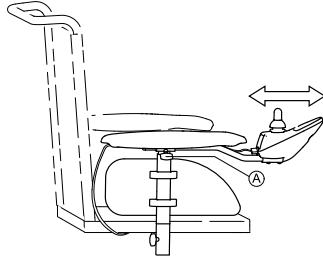

1. Loosen wing bolt (A).
2. Shift the remote forwards or backwards to the desired distance.
3. Retighten the bolt.

5.2.2 Adjusting the height of the remote (only for swing-away remote supports)



Tools:

- 6 mm Allen key

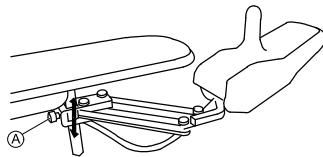

1. Loosen Allen screw (A).
2. Adjust remote to desired height.
3. Re-tighten Allen screw.

5.2.3 Swivelling the remote to the side

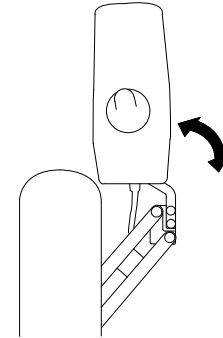

If your mobility device is fitted with a swing-away remote holder, then the remote can be moved away to the side, for example, to drive up close to a table.

5.3 Adjustment options for the Modulite seat unit

5.3.1 Adjusting the height of the armrests

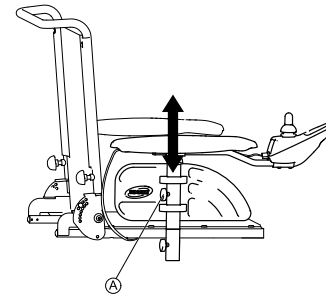

1. Loosen wing screw (A).
2. Adjust armrest to desired height.
3. Re-tighten wing screw.

5.3.2 Adjusting the width of the armrests



WARNING!

Serious injury hazard if one of the armrests falls out of its bracket because they have been adjusted to a width which exceeds the permissible value

- The width adjustment is fitted with small stickers with markings and the word "STOP". The armrests must never be pulled out further than the point at which the word "STOP" is completely legible.
- Always tighten the fixing screws properly once adjustments have been completed.



Depending on the side, the screw is accessible from the front or the rear.



Tools:

- 8 mm Allen key

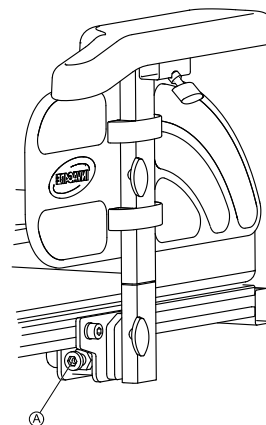

1. Loosen screw (A).
2. Adjust armrest to required position.
3. Retighten the screw.
4. Repeat this procedure for the second armrest.

5.3.3 Adjusting the position of the armrest in depth



Tools:

- 6 mm Allen key

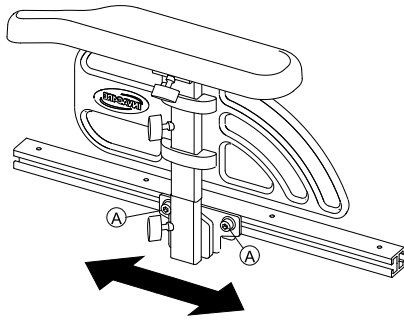

1. Loosen the screws **A** and move the armrest lengthwise.
2. Tighten the screws.

5.3.4 Adjusting the height (flip-up armrest)

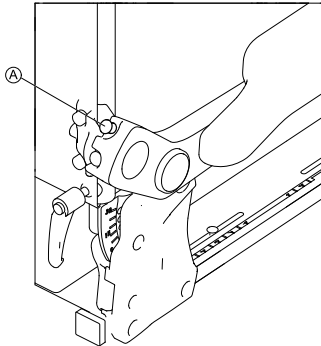

1. Loosen thumb screw **A**.
2. Adjust armrest to desired height.
3. Retighten thumb screw.

5.3.5 Adjusting the height (following armrest)



Tools:

- 5 mm Allen key
- 13 mm open-ended spanner

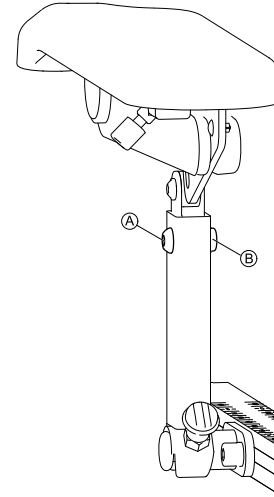

1. Loosen the screw **A** and nut **B** and remove them.
2. Adjust armrest to desired height.
3. Insert screw and nut and tighten.

5.3.6 Changing the resistance (flip-up/following armrest)

The movement of the flip-up and following armrests can be set to have greater or less resistance.

-  Tools:
- 5 mm Allen key

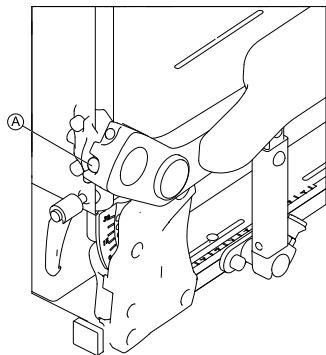

1. To make the armrest easier to move, release the screw **A** with the Allen key.
2. To make the armrest more difficult to move, tighten the screw **A** with the Allen key.

5.3.7 Adjusting the arm pad angle (flip-up/following armrest)

-  Tools:
- 5 mm Allen key

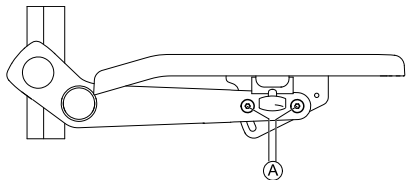

1. Loosen screws **A**.

 Do not remove them.

2. Adjust arm pad to desired angle.
3. Tighten screws.

5.3.8 Adjusting the position of the arm pad of the flip-up armrest

-  Tools:
- 5 mm Allen key

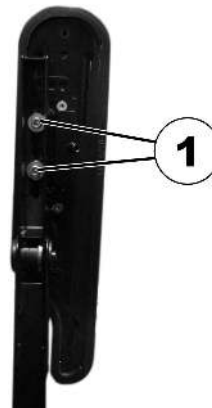

1. Put the armrest in the vertical position.
2. Release the interior bolts (**1**) with the Allen key.

3.

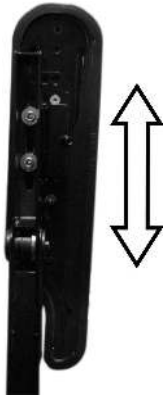

Position the armrest horizontally.

4. Re-tighten the bolts.
Make sure that the Nordlock washers used are re-inserted.

5.3.9 The hip support

The hip support can be combined with the flip-up armrest only.

Removing hip support

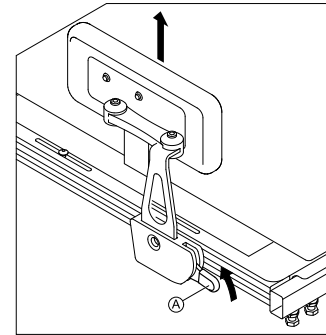

1. Pull lever **A** upwards.
2. Remove hip support from holder.

Inserting hip support

1. Insert hip support in holder.
2. Push lever **A** downwards.
Ensure that hip support locks with an audible click.

Adjusting position of hip support

-
-  Tools
- 5 mm Allen key
-

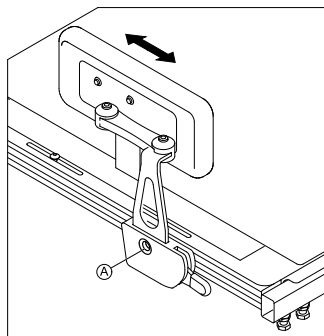

1. Loosen screw **A**.
Do not remove it.
2. Adjust hip support to desired position.
3. Tighten screw.

Adjusting width of hip support

-  Tools
- 2 x 5 mm Allen key

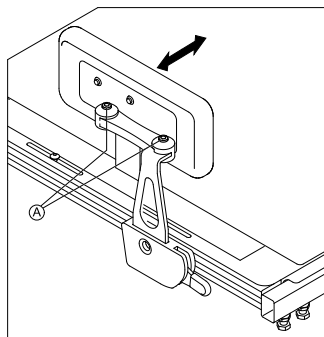

1. Loosen screws **A**.
2. Adjust hip support to desired width.

 You can adjust the width only smaller than the seat width but not wider.

3. Tighten screws.

Adjusting angle of hip support

-  Tools
- 5 mm Allen key

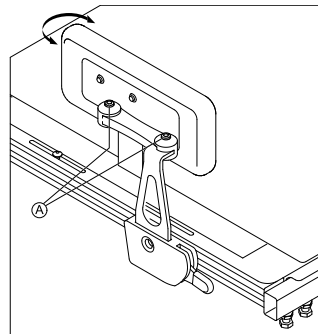

1. Loosen screws **A**.
2. Adjust hip support to desired angle.
3. Tighten screws.

Adjusting hip pad depth

-  Tools
- 10 mm open-ended wrench

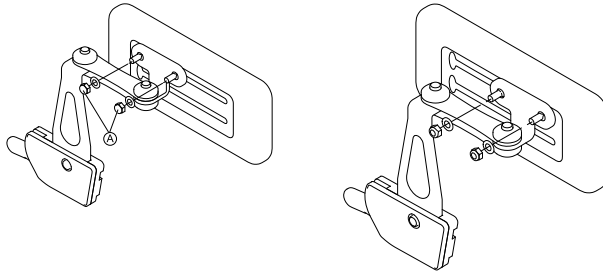

1. Loosen the two screws **A**.
2. Adjust hip pad to desired depth.
3. Tighten screws.

Adjusting hip pad height

You can adjust the hip pad height in two ways:

- Via its mounting slots.
- Via its bracket.

Via mounting slots



Tools

- 10 mm open-ended wrench

1.

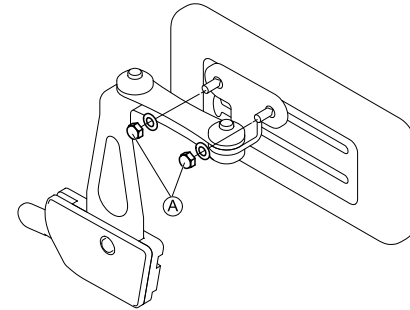

Loosen the two screws **A**.

2.

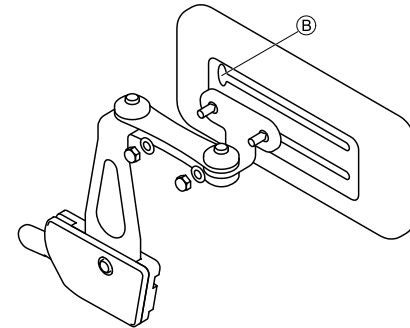

Remove hip pad bracket from mounting slot via cut-out **B**.

3. Insert hip pad bracket in other mounting slot.
4. Tighten screws.

Via bracket



Tools

- 5 mm Allen key

1.

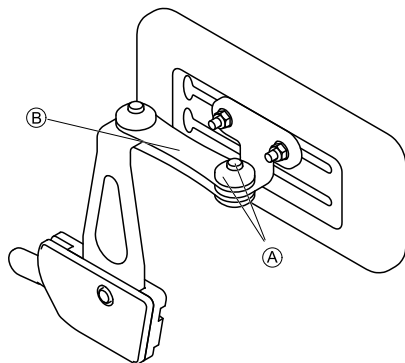

Remove upper screw and friction cap (A).

2. Remove small friction link (B).

3.

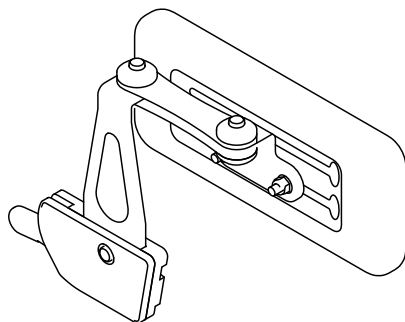

Remove hip pad with bracket, turn upside down and reinstall.

4. Insert friction link, friction cap, screw and tighten.

5.3.10 Adjusting the seat width

The telescopic seat support can be adjusted in four stages. The seat width can thus be adjusted together with the adjustable seat plate or the adjustable sling seat.

The description of how the width is adjusted is contained in the service instructions for this mobility device. The service instructions can be ordered from Invacare. However, they contain instructions for specially trained service technicians and describe operations that are not intended for the end user.

5.3.11 Adjusting the seat depth (Modulite seat unit)



The seat depth has a major influence on the selection of the center of gravity of the seat. This impacts its dynamic stability. If you make a major change to the seat depth the center of gravity of the seat must also be adjusted. See "Adjusting the center of gravity of the seat" in the service instructions for this mobility device. The service instructions can be ordered from Invacare. However, they contain instructions for specially trained technicians and describe operations that are not intended for the end user.



The numbers on the scale on the seat serve as a guide. They do not stipulate any dimensions such as seat depth in centimeters.



Tools:

- 6 mm Allen key

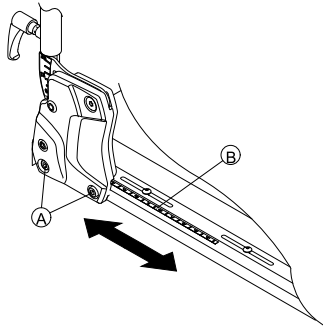

1. On both sides, loosen the bottom backrest screw (A).
Do not remove the screws!
2. Move the backrest to the required seat depth.
You can adjust the seat depth steplessly. Use scale (B) on the seat as a guide for this purpose.
Ensure that
 - a. the same seat depth is set on both sides.
 - b.

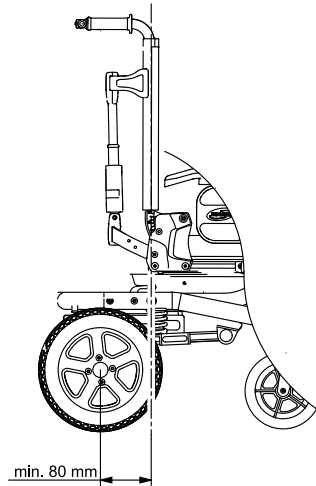

the distance between backrest and rear axle **ALWAYS** is at least 80 mm.

3. Re-tighten the screws.

5.4 Adjustment options for Max seat

5.4.1 Changing the armrest position



Requirements:

- 1 x 6 mm Allen key

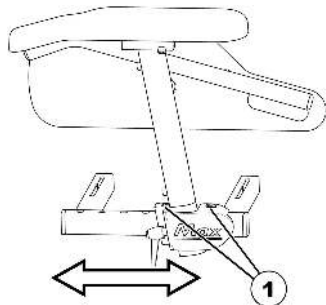

1. Loosen the screws (1) and remove them.
2. Position the armrest as desired.
If you cannot move the armrest, hit the clamping jaw slightly to loosen it.
3. Reposition the screws and tighten.

5.4.2 Setting the height of the armrests



Tools:

- 3 mm Allen key

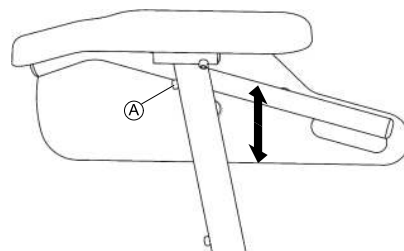

1. Unscrew screw (A) with Allen key.
2. Adjust armrest to required height.
3. Retighten the screw.

5.4.3 Adjusting the width of the armrests



Requirements:

- Allen key 8 mm

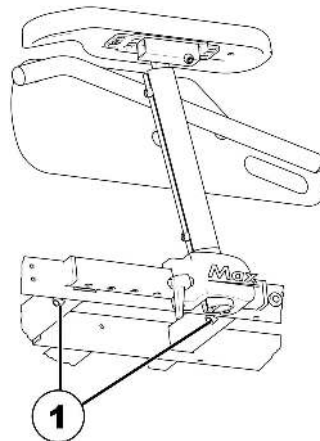

1. Loosen the screws (1).
2. Adjust the armrest to the desired width.
3. Retighten the screw.
4. Repeat this procedure for the second armrest.

5.4.4 Adjusting the seat depth



CAUTION!

Risk of damage to the power wheelchair if the sideways and central seat depth adjustment is not set identically

- When adjusting the seat depth, make sure to set identical values sideways and at the spindle or actuator for the backrest adjustment.



If necessary, you may shorten the seat depth by 130 mm using a seat depth adapter.



Requirements:

- Crosstip screwdriver
- 6 mm Allen key

1. Remove the seat cushion.
- 2.

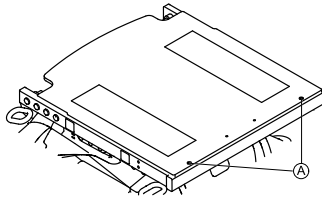

Loosen the screws (1) and remove the seat plate.

3.

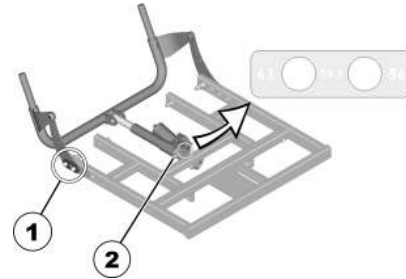

On both sides, remove the screws, washers, and cover plates (1).

4. Remove the screw (2).
5. Adjust the spindle or actuator for the backrest adjustment to the desired depth. In doing so, use the labelling on the spindle or actuator as guidance.
6. Retighten the screw (2).
- 7.

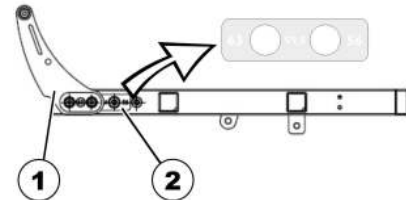

Adjust the bearing sheets (1) to the desired depth. In doing so, use the labelling on the seat as guidance (2).

8. Mount the cover plates and retighten the screws.
9. Mount the seat plate and replace the seat cushion.

5.5 Adjusting the seat angle



CAUTION!

Adjusting the seat tilt or the backrest angle changes the geometry of the mobility device and directly influences its dynamic stability!

- For details regarding dynamic stability, negotiating gradients and obstacles and the correct adjustment of seat tilt or backrest angle, refer to 6.5 Taking Obstacles, page 72 and 6.6 Driving up and down gradients, page 74.

5.5.1 Electrical

Consult the user manual for your remote for information about electrical adjustment.

5.5.2 Manual

The seat angle is adjusted using two perforated plates which are located right and left under the seat frames.



Requirements:

- 1 x open-ended spanner 1/2 inch

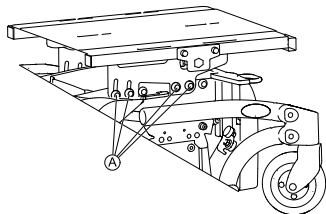

The picture shows the position of the screws **A** for manual seat angle adjustment.

1. Loosen all screws on both sides.
2. Set the required angle.
3. Retighten the screws.

5.6 Adjusting the backrest



CAUTION!

Adjusting the seat tilt or the backrest angle changes the geometry of the mobility device and directly influences its dynamic stability!

- For details regarding dynamic stability, negotiating gradients and obstacles and the correct adjustment of seat tilt or backrest angle, refer to 6.5 Taking Obstacles, page 72 and 6.6 Driving up and down gradients, page 74.

5.6.1 Adjusting the height of the backrest (Modulite seat unit)

The following section describes the procedures for adjusting the height of the backrest plate.



The sling back is only available in fixed heights of 48 and 54 cm.



Tools:

- 5 mm Allen key

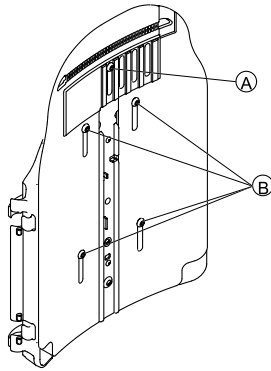

1. Loosen the backrest plate screws (A) and (B).
Do not remove the screws!
2. Move the backrest plate to the required height.
3. Re-tighten the screws.

5.6.2 Adjusting the width of the backrest (Modulite seat unit)

You can adjust the backrest plate width to a certain degree by adjusting the front plate, e.g. in order to adjust the backrest plate in line with the seat cushion. Fairly large adjustments must be made by a service technician to the rear plate and are outlined in the service instructions for this mobility device.



The sling back is only available in two widths of 38-43 cm and 48-53 cm and, under certain circumstances, must be replaced for a width adjustment. For a replacement description, see the service instructions for this mobility device. The service instructions can be ordered from Invacare. However, they contain instructions for specially trained service technicians and describe operations that are not intended for the end user.

Note that if the sling back width is adjusted the backrest cushion must also be replaced.



Tools:

- 5 mm Allen key

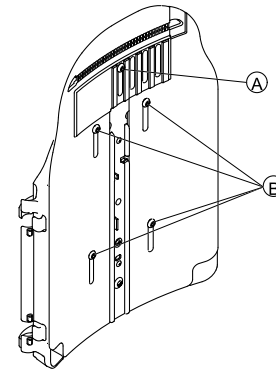

1. Loosen and remove the backrest plate screw (A).
2. Loosen the backrest plate screws (B).
Do not remove the screws!
3. Move the backrest plate halves to the required width.
4. Re-insert screw (A).
5. Re-tighten the screws.

5.6.3 Adjusting the backrest angle (Modulite seat unit)



CAUTION!

Every change to the seat angle and the backrest angle alters the geometry of the power wheelchair and affects its dynamic stability

- For more information on stability, overcoming obstacles correctly, driving along inclines and slopes and the correct position of the backrest and seat angles, see the section 6.5 Taking Obstacles, page 72 and 6.6 Driving up and down gradients, page 74.



CAUTION!

Risk of falling out of the wheelchair

When adjusting the backrest, it might move backward unexpectedly and you might fall out of the wheelchair.

- Do not rest against the backrest while adjusting it.



If the backrest is fitted with knobs instead of Allen screws, you do not need tools.

Width-adjustable backrest



Tools:

- 5 mm Allen key

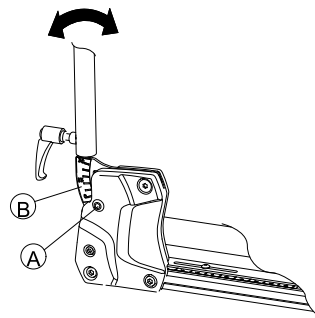

1. On both sides, loosen and remove the upper backrest screw (A).
2. Set the required backrest angle in 7.5° steps. Use scale (B) on the backrest for this purpose. Ensure that you set the same angle on both sides.
3. Re-insert and tighten the screw. Ensure you insert the screw through one of the holes of the backrest bracket. The screw must be visible on the inside of the bracket and the screw head must be flush with the bracket.

Simple backrest



Tools:

- 6 mm Allen key

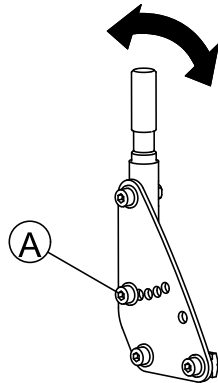

1. On both sides, loosen and remove the middle backrest screw (A).
2. Set the required backrest angle in 7.5° steps.
Ensure that you set the same angle on both sides.
3. Re-insert and tighten the screw.

5.6.4 Adjusting the backrest angle (Max seat)



Requirements:

- Crosstip screwdriver

1. Remove the backrest cushion and the seat cushion.

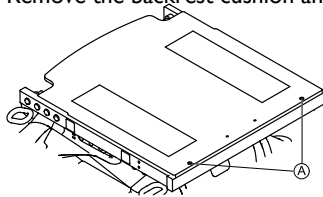

2. Loosen the screws (A) and remove the seat plate.

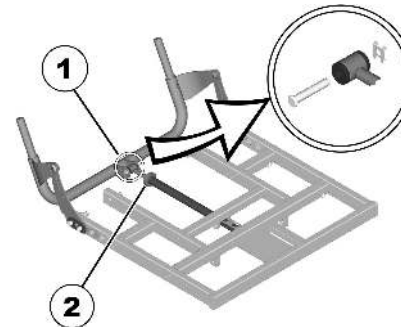

3. Remove the saving and the bolt (1).
4. Flip the backrest forward.
5. Loosen the knurled nut (2).
6. With the spindle, adjust the desired angle of the backrest.
Turning the spindle clockwise and inwards inclines the backrest backwards. Turning the spindle anti-clockwise and outwards inclines the backrest forwards.
7. With the bolt, reattach the spindle to the backrest tube and secure the bolt.
8. Mount the seat plate and replace the seat cushion.

5.6.5 Adjusting the tension adjustable backrest upholstery

1.



Remove the backrest cushion (attached with Velcro strips) by pulling it up and off to access the adjustment straps.

2.



Adjust the tension of the individual straps as desired.

3. Replace the backrest cushion.

5.6.6 Adjusting the backrest bend

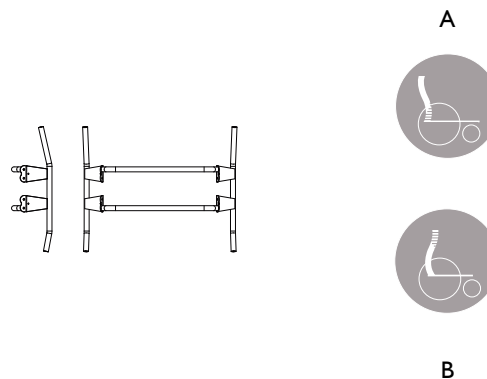
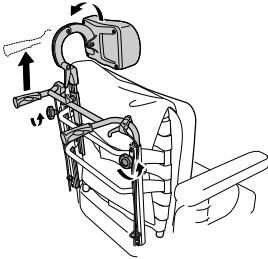

Figure 1

The backrest is designed with different angles as shown in figure 1. This allows for different adjustments according to how the backrest is mounted. Position A (the part of the backrest with the longer angle turned upwards) gives the user more room for the shoulder area while position B gives more room for the bottom.

1.



Loosen the handwheels **A** and raise the push handles as far as possible.

2.

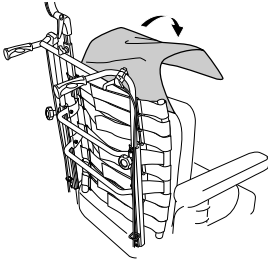

Remove the cushion.

3.

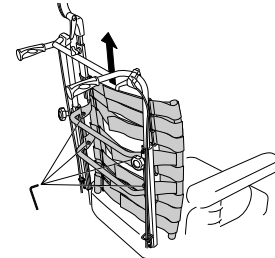

Loosen the screws **B** and remove the backrest by lifting upwards.

4.

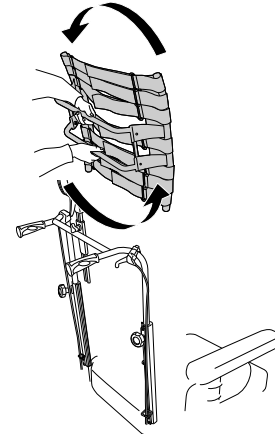

Turn the backrest 180°.

5.

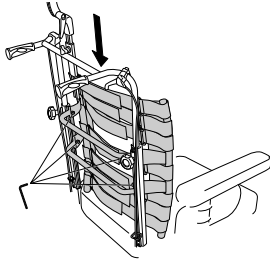

Put the backrest back by fitting it to the receivers on the tubes.
Tighten the screws.

6.

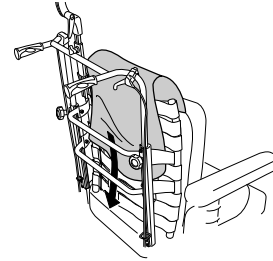

Put the cushion and cover back.

7.

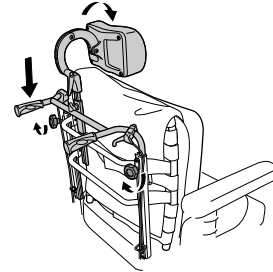

Lower the push handles and tighten the hand wheels.

5.7 Adjusting the headrest



CAUTION!

Injury hazard during use of the mobility device as a vehicle seat if a headrest is wrongly adjusted or not installed

This can cause the neck to be hyperextended during collisions.

- A headrest must be installed. The headrest optionally supplied for this mobility device by Invacare is perfectly suitable for use during transport.
- The headrest must be adjusted to the user's ear height.

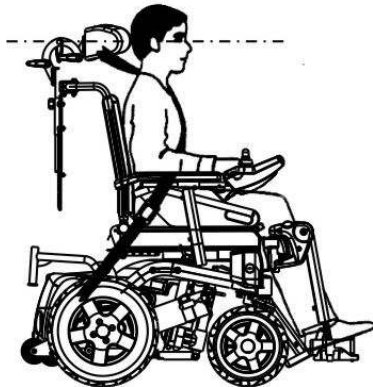

5.7.1 Adjusting the position of the headrest or neckrest

The adjustment of the position is the same for all headrests and neckrests.



Tools:

- 5 mm Allen key

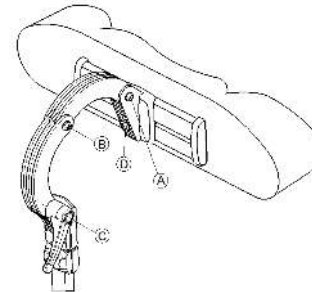

1. Loosen the screws **A** , **B** or the clamping lever **C**.
2. Adjust the headrest or neckrest to the required position.
3. Retighten screws and clamping lever.
4. Loosen the Allen screw **D**.
5. Slide the headrest left or right to the required position.
6. Retighten the Allen screw.

5.7.2 Adjusting the height of the headrest or neckrest

The adjustment of the height is the same for all headrests and neckrests.

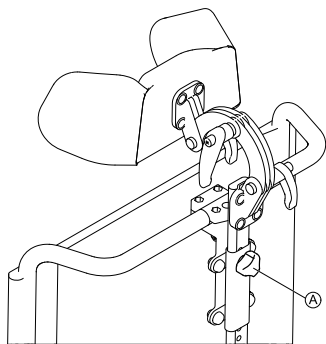

1. Loosen knob **A**.
2. Adjust headrest or neckrest to required height.
3. Retighten knob.

5.7.3 Adjusting the cheek supports



1. Push the cheek supports inward or pull them out to the required position.

5.8 Adjusting the trunk supports

5.8.1 Adjusting the width

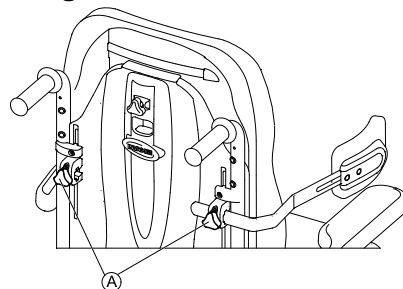

1. Loosen the knobs **A** that hold the lateral supports.
2. Adjust the supports to the desired width.
3. Re-tighten the knobs.

5.8.2 Adjusting the height



Requirements:

- Allen key 5 mm

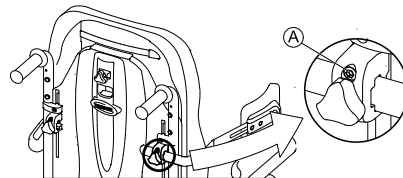

1. Loosen the screws **A** that allow height adjustment of the lateral supports.
2. Adjust the supports to the desired height.
3. Re-tighten the screws.

5.8.3 Adjusting the depth



Requirements:

- Allen key 5 mm

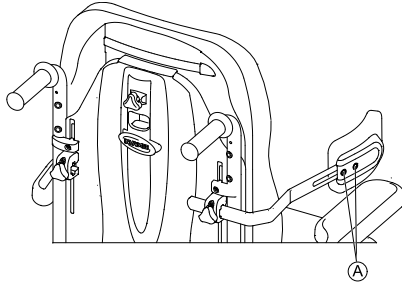

1. Loosen the screws (A) that allows the support pads to slide forwards and backwards.
2. Adjust the supports to the desired position.
3. Re-tighten the screws.

5.9 Adjusting and removing the tray



CAUTION!

Injury hazard or material damage if a mobility device which is fitted with a table is transported in a vehicle

- If a table is fitted, always remove it before transporting the mobility device.



5.9.1 Laterally adjusting the tray

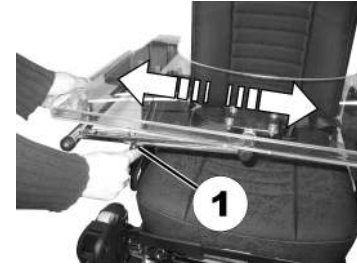

1. Loosen wing-screw (1).
2. Adjust tray towards the left or right.
3. Re-tighten wing-screw.

5.9.2 Adjusting the depth of the tray / removing the tray

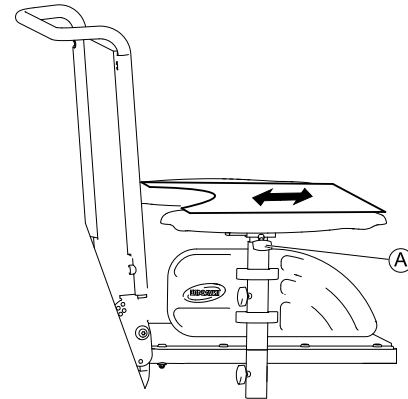

1. Loosen wing-screw (A).
2. Adjust tray to desired depth (or remove it entirely).
3. Re-tighten screw.

5.9.3 Swinging the tray away to the side

The tray can be swivelled up and away to the side to allow the user to get in and out of the mobility device.



CAUTION!

Risk of injury! When the tray is raised it does not lock in place in this position!

- Do not tilt the tray up and leave it leaning in this position.
- Never attempt to drive with the tray tilted up.
- Always lower the tray in a controlled manner.

5.10 Center-mounted legrests — manually adjustable



Electric

- Please consult the user manual for your remote for information about electrical adjustment.

5.10.1 Removing the leg rest

You can remove the central, manually adjustable leg rest completely.

1.

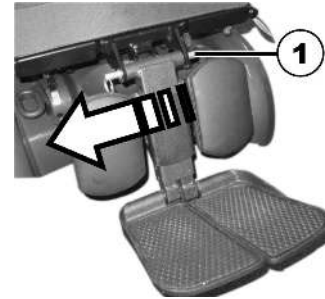

Remove the removable axle (1).

2.



Hold the leg rest securely and pull the lever (1).

3. Remove the leg rest from the holder (2).

5.10.2 Setting the angle of the leg rest



CAUTION!

Risk of injury

If the leg rest is not secured and the lever (1) is removed, the leg rest will drop suddenly, which could cause an injury.

- Secure the leg rest before you remove the lever to adjust the angle of the leg rest.



1. Hold the leg rest securely.
2. Pull the lever (1).
3. Push the leg rest into the required position.

5.10.3 Setting the length of the leg rest

-  Tools:
- 3/16" (4.8 mm) Allen key
-

You can adjust the length of the leg rests independently of one another.

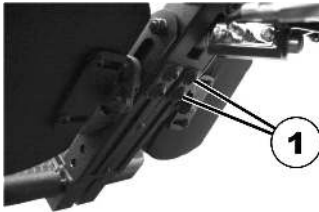

1. Release the bolts (1) on the rear of the leg rest using the Allen key.
2. Set the desired length.
3. Retighten the bolts.

5.10.4 Setting the angle of the footplate

-  Tools:
- 5/32" (4 mm) Allen key
-



1. Fold the footplates up in order to access the adjusting screws (1).
2. Set the adjusting screws using the Allen key.
3. Fold the footplate down again.

5.10.5 Setting the angle and height of the calf pad

-  Tools:
- 3/16" (4.8 mm) Allen key
-



1. Fold the calf pad forward in order to access the bolt (1).
2. Loosen the bolt using the Allen key and adjust the calf pad to the required angle and height.
3. Retighten the bolt.
4. Fold the calf pad back.

5.11 Vari-F footrest

5.11.1 Swivelling the footrest/legrest outward and/or removing

The small unlocking button is located on the upper section of the footrest/legrest. When the footrest/legrest is unlocked, it can be swivelled inward or outward when getting into the wheelchair as well as being removed completely.

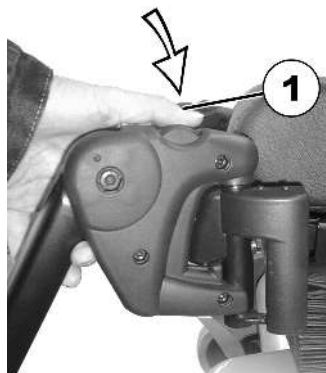

1. Press the unlocking button (1) and swivel the footrest/legrest outward.
2. Remove the footrest/legrest in an upward direction.

5.11.2 Setting the angle



CAUTION!

Risk of injury due to incorrect adjustment of the footrests and legrests

- Before and during every journey it is imperative to ensure that the legrests contact neither the caster wheels nor the ground



Tools:

- 6 mm Allen key

1.

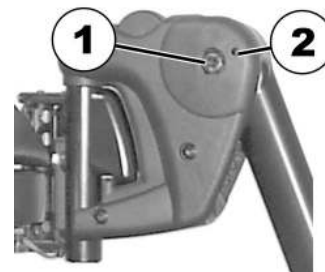

- Loosen the screw (1) using the Allen key.
2. If the footrest cannot be moved after loosening the screw, position a metal pin in the designated borehole (2) and use a hammer to knock on this lightly. The clamping mechanism in the interior of the footrest will be released by this. Repeat the procedure from the other side of the footrest if necessary.

3.



Loosen the screw (1) using the Allen key.

4. Set the desired angle.
5. Re-tighten the screw.

5.11.3 Setting the end stop of the footrest



Tools:

- 6 mm Allen key
- 10 mm open-ended spanner

1.



The end position of the footrest is determined by means of a rubber stop (1).

2.

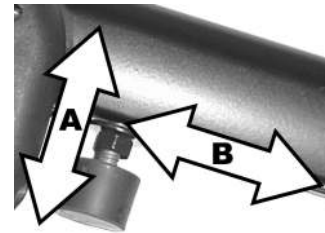

The rubber stop can be screwed in or out (A) or pushed up or down (B).

3.



Use the Allen key to loosen the screw (1) and swivel the footrest upward in order to access the rubber stop.

4.



Use the open-ended spanner to loosen the counter nut (1).

5.

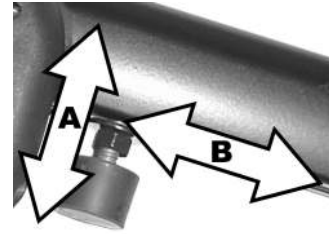

Move the rubber stop to the desired position.

6. Re-tighten the counter nut.

7.

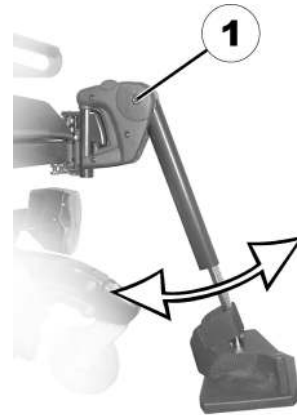

Move the footrest to the desired position.

8. Re-tighten the screw.

5.11.4 Adjusting the length of the legrest



CAUTION!

Risk of injury due to incorrect adjustment of the footrests and legrests

- Before and during every journey it is imperative to ensure that the legrests contact neither the caster wheels nor the ground



Tools:

- 5 mm Allen key

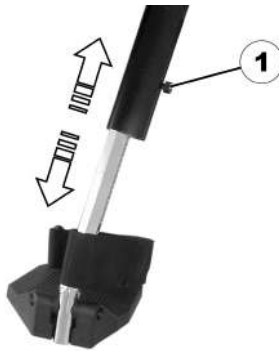

1. Use the spanner to loosen the screw (1).
2. Adjust to the desired length.
3. Re-tighten the screw.

5.12 Vari-A legrests

5.12.1 Swivelling the footrest/legrest outward and/or removing

The small unlocking button is located on the upper section of the footrest/legrest. When the footrest/legrest is unlocked, it can be swivelled inward or outward when getting into the wheelchair as well as being removed completely.

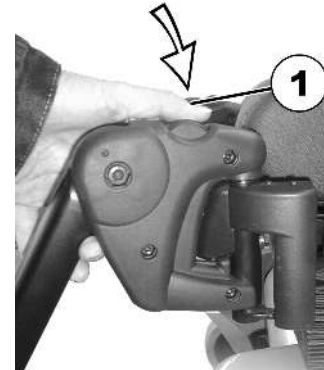

1. Press the unlocking button (1) and swivel the footrest/legrest outward.
2. Remove the footrest/legrest in an upward direction.

5.12.2 Setting the angle



CAUTION!

Risk of injury due to incorrect adjustment of the footrests and legrests

- Before and during every journey it is imperative to ensure that the legrests contact neither the caster wheels nor the ground

1.

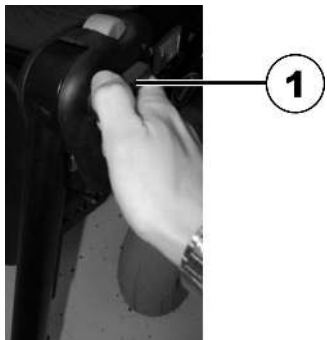

Loosen the locking knob (1) counter-clockwise at least one turn.

2.



Hit the knob to release the locking mechanism.

3.



Set the desired angle.

4.



Turn the knob clockwise to tighten it.

5.12.3 Setting the end stop of the legrest



Tools:

- 10 mm open-ended spanner

1.



The end position of the legrest is determined by means of a rubber stop (1).

2.

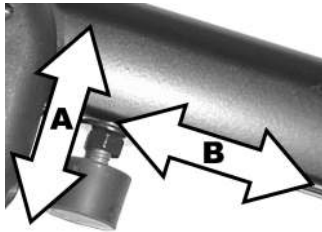

The rubber stop can be screwed in or out (A) or pushed up or down (B).

3.

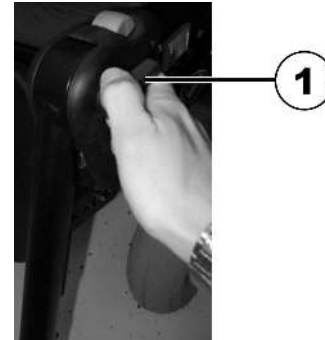

Loosen the locking knob (1) counter-clockwise at least one turn.

4.



Hit the knob to release the locking mechanism.

5.

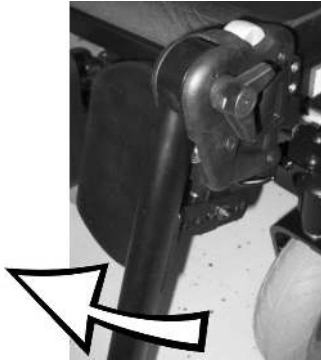

Swivel the legrest upward in order to access the rubber stop.

6.



Use the open-ended spanner to loosen the counter nut (1).

7.

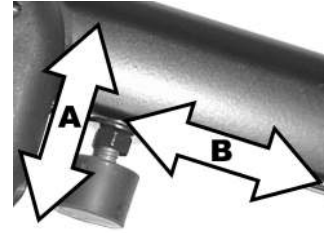

Move the rubber stop to the desired position.

8. Re-tighten the counter nut.

9.



Move the legrest to the desired position.

10. Re-tighten the locking knob.

5.12.4 Adjusting the length of the legrest



CAUTION!

Risk of injury due to incorrect adjustment of the footrests and legrests

- Before and during every journey it is imperative to ensure that the legrests contact neither the caster wheels nor the ground



Tools:

- 5 mm Allen key

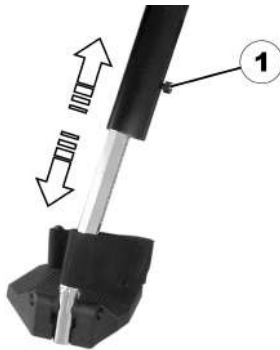

1. Use the spanner to loosen the screw (1).
2. Adjust to the desired length.
3. Re-tighten the screw.

5.12.5 Adjusting the depth of the calf pad

The depth of the calf pad can be adjusted via the holding plate. The holding plate hole combinations allow 5 different depth settings.



Tools:

- 10 mm open-ended spanner



1. Use the open-ended spanner to loosen the nut (1) and remove.
2. Adjust to the desired depth. Please observe that the round holes are intended for the calf pad retaining screw and the oblong holes for the aglet without thread.
3. Screw the nut back on and tighten.

5.12.6 Adjusting the height of the calf pad



Tools:

- 4 mm Allen key



1. Use the Allen key to loosen the screws (1).
2. Adjust to the desired position.
3. Re-tighten the screws.

5.12.7 Unlocking and swivelling the calf pad backward when alighting

1.



2. Press the calf pad straight down.

2.



Unlock the legrest and swivel outward.
The calf pad swivels backward on its own.

3.



Lift leg over the heel strap and place on the ground.

5.12.8 Adjusting the angle-adjustable foot plate



Tools:

- 5 mm Allen key



1. Use the Allen key to loosen both set screws on the foot plate.
2. Adjust to the desired angle.
3. Re-tighten the screws.

5.12.9 Adjusting the angle- and depth-adjustable foot plate



Tools:

- 5 mm Allen key



1. Use the Allen key to loosen the set screw on the foot plate (1).
2. Adjust the foot plate to the desired angle or depth.
3. Re-tighten the screw.

5.13 ADM legrests

5.13.1 Swivelling the footrest/legrest outward and/or removing

The small unlocking button is located on the upper section of the footrest/legrest. When the footrest/legrest is unlocked, it can be swivelled inward or outward when getting into the wheelchair as well as being removed completely.

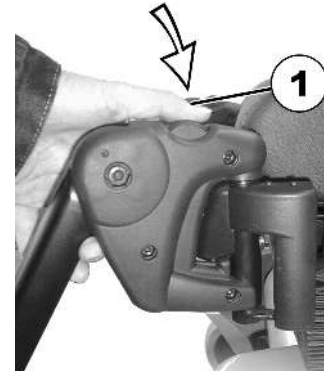

1. Press the unlocking button (1) and swivel the footrest/legrest outward.
2. Remove the footrest/legrest in an upward direction.

5.13.2 Setting the angle



CAUTION!

Risk of crushing

– Do not reach inside the swivelling range of the legrest.



CAUTION!

Risk of injury due to incorrect adjustment of the footrests and legrests

- Before and during every journey it is imperative to ensure that the legrests contact neither the caster wheels nor the ground

Raising



1. Pull the legrest upward until the desired angle has been achieved.

Lowering

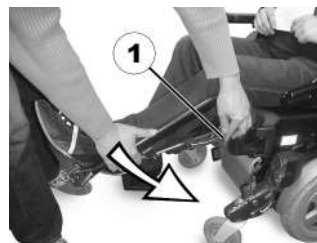

1. Keep the legrest in the foot plate area, pull the lateral adjusting lever (1) and lower the legrest slowly.

5.13.3 Adjusting the length of the legrest



CAUTION!

Risk of injury due to incorrect adjustment of the footrests and legrests

- Before and during every journey it is imperative to ensure that the legrests contact neither the caster wheels nor the ground



Tools:

- 5 mm Allen key

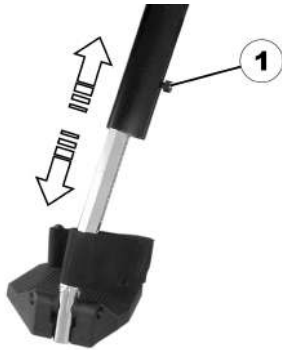

1. Use the spanner to loosen the screw (1).
2. Adjust to the desired length.
3. Re-tighten the screw.

5.13.4 Adjusting the depth of the calf pad

The depth of the calf pad can be adjusted via the holding plate. The holding plate hole combinations allow 5 different depth settings.



Tools:

- 10 mm open-ended spanner



1. Use the open-ended spanner to loosen the nut (1) and remove.
2. Adjust to the desired depth. Please observe that the round holes are intended for the calf pad retaining screw and the oblong holes for the aglet without thread.
3. Screw the nut back on and tighten.

5.13.5 Adjusting the height of the calf pad



Tools:

- 4 mm Allen key



1. Use the Allen key to loosen the screws (1).
2. Adjust to the desired position.
3. Re-tighten the screws.

5.13.6 Unlocking and swivelling the calf pad backward when alighting

1.



2. Press the calf pad straight down.

2.



Unlock the legrest and swivel outward.
The calf pad swivels backward on its own.

3.



Lift leg over the heel strap and place on the ground.

5.13.7 Adjusting the angle-adjustable foot plate



Tools:

- 5 mm Allen key



1. Use the Allen key to loosen both set screws on the foot plate.
2. Adjust to the desired angle.
3. Re-tighten the screws.

5.13.8 Adjusting the angle- and depth-adjustable foot plate



Tools:

- 5 mm Allen key



1. Use the Allen key to loosen the set screw on the foot plate (1).
2. Adjust the foot plate to the desired angle or depth.
3. Re-tighten the screw.

5.14 Powered elevating legrests (ADE legrests)

5.14.1 Swivelling the legrest outward and/or removing

The small unlocking button is located on the upper section of the legrest. When the legrest is unlocked, it can be swivelled inward or outward when getting into wheelchair as well as being removed completely.



1. Press the unlocking button (1) and swivel the legrest outward.
2. Remove the legrest in an upward direction.

5.14.2 Setting the angle



CAUTION!

Risk of crushing

– Do not reach inside the swivelling range of the legrest.



CAUTION!

Risk of injury due to incorrect adjustment of the footrests and legrests

- Before and during every journey it is imperative to ensure that the legrests contact neither the caster wheels nor the ground

The electrically height-adjustable legrests are operated using the remote. Refer to the separate user manual for your remote for more information.

5.14.3 Adjusting the length of the legrest



CAUTION!

Risk of injury due to incorrect adjustment of the footrests and legrests

- Before and during every journey it is imperative to ensure that the legrests contact neither the caster wheels nor the ground



Tools:

- 10 mm open-ended spanner



1. Use the spanner to loosen the screw (1).
2. Adjust to the desired length.
3. Re-tighten the screw.

5.14.4 Adjusting the depth of the calf pad

The depth of the calf pad can be adjusted via the holding plate. The holding plate hole combinations allow 5 different depth settings.



Tools:

- 10 mm open-ended spanner



1. Use the open-ended spanner to loosen the nut (1) and remove.
2. Adjust to the desired depth. Please observe that the round holes are intended for the calf pad retaining screw and the oblong holes for the aglet without thread.
3. Screw the nut back on and tighten.

5.14.5 Adjusting the height of the calf pad



Tools:

- 4 mm Allen key



1. Use the Allen key to loosen the screws (1).
2. Adjust to the desired position.
3. Re-tighten the screws.

5.14.6 Unlocking and swivelling the calf pad backward when alighting

- 1.



Press the calf pad straight down.

- 2.



Unlock the legrest and swivel outward.
The calf pad swivels backward on its own.

- 3.



Lift leg over the heel strap and place on the ground.

5.14.7 Adjusting the angle-adjustable foot plate



Tools:

- 5 mm Allen key



1. Use the Allen key to loosen both set screws on the foot plate.
2. Adjust to the desired angle.
3. Re-tighten the screws.

5.14.8 Adjusting the angle- and depth-adjustable foot plate



Tools:

- 5 mm Allen key



1. Use the Allen key to loosen the set screw on the foot plate (1).
2. Adjust the foot plate to the desired angle or depth.
3. Re-tighten the screw.

5.15 Legrests for Max seat

5.15.1 Adjusting the height of the calf pad



Requirements:

- Crosstip screwdriver



1. Remove the cushion of the calf pad.

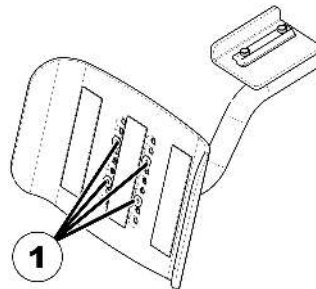

2. Loosen the screws (1) using the crosstip screwdriver and remove them.

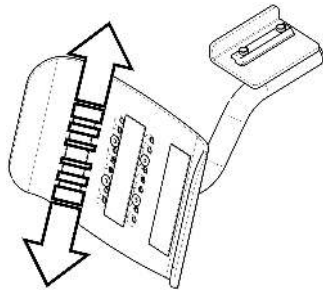

3. Move the calf pad to the desired position.
4. Re-insert the screws and tighten.

5.15.2 Adjusting the calf pad width



Requirements:

- 4 mm Allen key

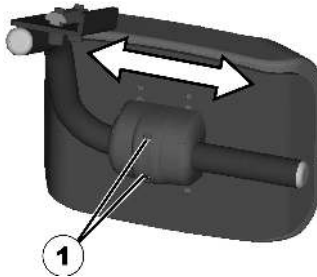

1. Loosen the Allen screws (1) using the Allen key.
2. Set the calf pad to the desired position.
3. Re-tighten the screws.

5.15.3 Adjusting the length of the legrest



CAUTION!

Risk of injury due to incorrect adjustment of the footrests and legrests

- Before and during every journey it is imperative to ensure that the legrests contact neither the caster wheels nor the ground



Tools:

- 5 mm Allen key

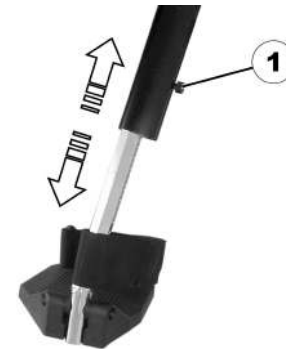

1. Use the spanner to loosen the screw (1).
2. Adjust to the desired length.
3. Re-tighten the screw.

5.16 Adjusting the width of side-mounted legrests



Tools:

- 13 mm open-ended spanner
-



The screws that allow width adjustment of side-mounted legrests are located under the seat (1).

1. Loosen the screws using the open-end spanner.
2. Adjust the legrest to the desired position.
3. Re-tighten the screws.

6 Usage

6.1 Driving



CAUTION!

Risk of unexpected driving behavior due to locked casters

If your mobility device is fitted with caster locks and these are locked, the casters cannot move freely and the mobility device might therefore not react to your steering as it should.

- Make sure the caster locks are unlocked before driving.



The maximum load capacity that is stated in the technical data only states that the system is designed for this mass in total. However, this does not mean that one can sit a person with this body weight in the mobility device without restrictions. Attention must be paid to the body proportions, such as height, weight distribution, abdominal belt, leg and calf strap and seat depth. These factors have a strong influence on driving features such as tilt stability and traction. The permissible axle loads in particular must be adhered to (refer to II Technical data, page 96). It may possibly be necessary to carry out adaptations to the seat system.

6.2 Before driving for the first time

Before you take your first trip, you should familiarize yourself well with the operation of the mobility device and with all operating elements. Take your time to test all functions and driving modes.



If installed, make sure to properly adjust and use the postural belt each time you use the mobility device.

Sitting comfortably = Driving safely

Before each trip, make sure that:

- You are within easy reach of all operating controls.
- The battery charge is sufficient for the distance intended to be covered.
- The postural belt (if installed) is in perfect order.
- The rear mirror (if installed) is adjusted so you can look behind at all times without having to bend forward or shift your seating position.

6.3 Parking and stationary

When parking your vehicle or if your vehicle is stationary for a prolonged period:

1. Switch the vehicle's power system off (ON-/OFF key).
2. Activate your anti-theft lock, if existing.

6.4 Getting in and out of the mobility device



- The armrest must be removed or swiveled up in order to get into or out of the mobility device from the side.

6.4.1 Removing the standard armrest in order to side transfer

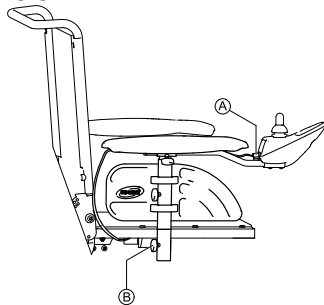

1. Pull the plug **A** of the remote cable to disconnect the remote.
2. Loosen wing nut **B**.
3. Remove the armrest from the holder.

6.4.2 Information about getting in and out



WARNING!

Risk of serious injury or damage

Improper transfer techniques may cause serious injury or damage

- Before attempting transfers, consult a healthcare professional to determine proper transfer techniques for the user and type of wheelchair.
- Follow the instructions below.



If you do not have sufficient muscle strength, you should ask other persons for help. Use a sliding board, if possible.

Getting into the mobility device:

1. Position your mobility device as close as possible to your seat. This might have to be done by an attendant.
2. Align casters parallel to the drive wheels to improve stability during transfer.
3. Always switch your mobility device off.
4. Always engage both motor locks/clutches and free wheel hubs (if fitted) to prevent the wheels from moving.
5. Depending on the armrest type of your mobility device, detach the armrest or swivel it up.
6. Now slide into the mobility device.

Getting out of the mobility device:

1. Position your mobility device as close as possible to your seat.
2. Align casters parallel to the drive wheels to improve stability during transfer.
3. Always switch your mobility device off.
4. Always engage both motor locks/clutches and free wheel hubs (if fitted) to prevent the wheels from moving.
5. Depending on the armrest type of your mobility device, detach the armrest or swivel it up.
6. Now slide onto your new seat.

6.5 Taking Obstacles

6.5.1 The "SureStep" System

This mobility device is fitted with "SureStep" technology. When climbing over obstacles, the casters retract and raise. They extend and lower when descending.

6.5.2 Maximum obstacle height

You can find information about maximum obstacle heights in the chapter entitled II Technical data, page 96.

6.5.3 Safety information when taking obstacles



CAUTION! **Risk of tipping over**

- Never approach obstacles at an angle but at 90 degrees as shown below.
- Approach obstacles with a gradient after it with caution. If unsure whether the gradient is too steep or not, move away from the obstacle and if possible try to find another location.
- Never approach obstacles at an uneven and/or loose ground.
- Never drive with too low tire pressure. For the recommended tire pressure, refer to II Technical data, page 96.
- Put your backrest into an upright position before ascending an obstacle.



CAUTION!

Risk of falling out of the mobility device and damage to the mobility device such as broken casters

- Never approach obstacles that are higher than the maximum climbable obstacle height. For the maximum climbable obstacle height, refer to II Technical data, page 96.
- Never let the footrest/legrest touch the ground when descending an obstacle.
- If unsure whether taking an obstacle is possible or not, move away from the obstacle and if possible find another location.

6.5.4 The correct way to overcome obstacles

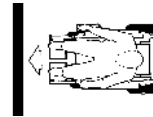

Right



Wrong

Ascending

1. Approach the obstacle or the curb slowly, head-on and at a right angle.
2. Depending on the wheel drive type, stop in one of the following positions:
 - a. In the case of centrally driven mobility devices: 5 - 10 cm before the obstacle.
 - b. For all other drives: approx. 30 - 50 cm in front of the obstacle.

3. Check the position of the front wheels. They must be in driving direction and at right angles to the obstacle.
4. Approach slowly and keep at a consistent speed until the rear wheels have also passed over the obstacle.

Descending

The approach to descend an obstacle is the same as to ascend it with the difference that you need not to stop before descending.

1. Descend the obstacle with medium speed.



When descending an obstacle too slowly it could happen that the antitippers get stuck and lift the drive wheels off the ground. A driving of the mobility device is then no longer possible.

Ascending obstacles with a curb climber

1. Approach the obstacle or the curb slowly, head-on and at a right angle.
2. Stop in the following position: 30 – 50 cm in front of the obstacle.
3. Check the position of the front wheels. They must be in driving direction and at right angles to the obstacle.
4. Approach with full speed until the curb climber makes contact with the obstacle. The impetus will lift both front wheels over the obstacle.
5. Keep at a consistent speed until the rear wheels have also passed over the obstacle.

6.6 Driving up and down gradients

For information concerning the maximum safe slope, refer to II Technical data, page 96.



CAUTION!

Risk of tipping over

- Only ever drive downhill at a maximum of 2/3 of the top speed. Avoid sudden changes of direction or abrupt braking when driving on slopes.
- Always return the backrest of your seat or the seat tilt (if adjustable seat tilt is available) to an upright position before ascending slopes. We recommend that you position the seat backrest or the seat tilt slightly to the rear before descending slopes.
- Always lower the lifter (if fitted) to its lowest position before ascending or descending a slope.
- Never attempt to ascend or descend a slope on slippery surfaces or where there is a risk of skidding (such as wet pavement, ice etc).
- Avoid trying to get out of the vehicle on an incline or a gradient.
- Always drive straight in the direction the road or path you are on goes, rather than attempting to zigzag.
- Never attempt to turn around on an incline or a slope.



CAUTION!

Braking distance is much longer on a downhill slope than on even terrain

- Never drive down a slope that exceeds the maximum safe slope (refer to II Technical data, page 96).

6.7 Use on public roads

If you wish to use your mobility device on public roads and lighting is required by national legislation, then your mobility device needs to be fitted with an appropriate lighting system.

Contact your Invacare dealer if you have any questions.

6.8 Pushing the mobility device in freewheel mode

The motors of the mobility device are equipped with automatic brakes, preventing that the mobility device starts rolling out of control when the remote is switched off. When pushing the mobility device manually whilst freewheeling, the magnetic brakes must be disengaged.

 Pushing the mobility device by hand may require more physical force than expected (more than 100 N). The necessary force nevertheless complies with the requirements of ISO 7176-14.

6.8.1 Disengaging motors



CAUTION!

Risk of the mobility device running away

– When the motors are disengaged (for push operation whilst freewheeling), the electromagnetic motor brakes are deactivated. When the mobility device is parked, the levers for engaging and disengaging the motors must without fail be locked firmly into the "DRIVE" position (electromagnetic motor brakes activated).

 The motors may only be disengaged by an attendant, not by the user.

This ensures that the motors are only disengaged if an attendant is available to secure the mobility device and prevent unintended rolling.

The lever for disengaging the motors is located behind the motors.

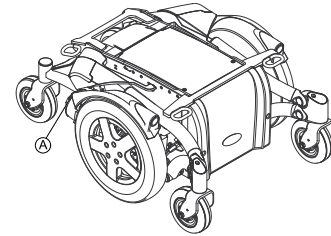

Disengaging motors

1. Switch off remote.
2. Turn the engaging lever  down. The motors are now disengaged.

Re-engaging motors

1. Turn the engaging lever  upwards. The motors are now re-engaged.

7 Electrical system

7.1 Electronics protection system

The vehicle drive electronics is fitted with an overload protection.

If the drive is severely overloaded over a long period (for example, during steep climbs) and, above all, at simultaneous high external temperatures, the electronic system can overheat. In this case, the vehicle performance is gradually reduced until it comes to a standstill. The status display shows a corresponding flash code (please refer to the user manual for your remote). If you switch the drive electronics off and then on again, the error message is deleted and the electronics can be switched on again. It can however take up to five minutes until the electronics has cooled down enough for the drives to apply their full performance.

If the drive is blocked due to an insurmountable obstacle, for example, a curb or similar which is too high, and the driver attempts to run the drive for more than 20 seconds against this obstacle, the electronic system switches the drives off to avoid damage. The status display shows a corresponding flash code (please refer to the user manual for your remote). If you switch the drive electronics off and then on again, the error message is deleted and the electronics can be switched on again.



A defective main fuse may be replaced only after checking the entire electric system. An specialized Invacare dealer must perform the replacement. You can find information on the fuse type in 11 Technical data, page 96.

7.2 Batteries

Power is supplied by two 12 V batteries. The batteries are maintenance-free and only need regular charging.

In the following, you find information on how to charge, handle, transport, store, maintain, and use batteries.

7.2.1 General information on charging

New batteries should always be fully charged once before their first use. New batteries will be at their full capacity after having run through approx. 10 - 20 charging cycles (break-in period). This break-in period is necessary to fully activate the battery for maximum performance and longevity. Thus, range and running time of your mobility device could initially increase with use.

Gel/AGM lead acid batteries do not have a memory effect as NiCd batteries.

7.2.2 General instructions on charging

Follow the instructions listed below to ensure safe use and longevity of the batteries:

- Charge 18 hours prior to initial usage.
- We recommend charging the batteries daily after every discharge even after partly discharge, as well as each night over night. Depending on the level of discharge, it can take up to 12 hours until the batteries are fully charged again.
- When the battery indicator reached the red LED range, charge the batteries for 16 hours minimum, neglecting the charge complete display!
- Try to provide a 24 hour charge once a week to make sure that both batteries are fully charged.
- Do not cycle your batteries at a low state of charge without regularly recharging them fully.
- Do not charge your batteries under extreme temperatures. High temperatures above 30 °C are not recommended for charging as well as low temperatures below 10 °C.

- Use only charging devices in Class 2. This class of chargers may be left unattended during charging. All charging devices which are supplied by Invacare comply with these requirements.
- You cannot overcharge the batteries when using the charger supplied with your mobility device, or a charger that has been approved by Invacare.
- Protect your charger from sources of heat such as heaters and direct sunlight. If the battery charger overheats, charging current will be reduced and the charging process delayed.

7.2.3 How to charge the batteries

Refer to the user manuals for your remote and battery charger for the position of the charging socket and further information about charging the batteries.



WARNING!

Risk of explosion and destruction of batteries if the wrong battery charger is used

- Only ever use the battery charger supplied with your mobility device, or a charger that has been approved by Invacare.



WARNING!

Risk of electric shock and damage to the battery charger if it gets wet

- Protect the battery charger from water.
- Always charge in a dry environment.



WARNING!

Risk of short circuit and electric shock if the battery charger has been damaged

- Do not use the battery charger if it has been dropped or damaged.



WARNING!

Risk of electric shock and damage to the batteries

- NEVER attempt to recharge the batteries by attaching cables directly to the battery terminals.



WARNING!

Risk of fire and electric shock if a damaged extension cable is used

- Only ever use an extension cable if it is absolutely necessary. In case you must use one, make sure it is in good condition.



WARNING!

Risk of injury if using the mobility device during charging

- DO NOT attempt to recharge the batteries and operate the mobility device at the same time.
- DO NOT sit in the mobility device while charging the batteries.

1. Switch off the mobility device.
2. Connect the battery charger to the charger socket.
3. Connect the battery charger to the power supply.

7.2.4 How to disconnect the mobility device after charging

1. Once charging is complete, first disconnect the battery charger from the power supply, then disconnect the plug from the remote.

7.2.5 Storage and Maintenance

Follow the instructions listed below to ensure safe use and longevity of the batteries:

- Always store the batteries fully charged.
- Do not leave the batteries in a low state of charge for an extended length of time. Charge a discharged battery as soon as possible.
- In case your mobility device is not used for a longer period of time (that is more than two weeks), the batteries must be charged at least once a month to maintain a full charge and always be charged before use.
- Avoid hot and cold extremes when storing. We recommend to store batteries at a temperature of 15 °C.
- Gel and AGM batteries are maintenance-free. Any performance issues should be handled by a properly trained mobility device technician.

7.2.6 Instructions on using the batteries



CAUTION!

Risk of damaging the batteries.

- Avoid ultra-deep discharges and never drain your batteries completely.

- Pay attention to the Battery Charge Indicator! Charge the batteries when the Battery Charge Indicator shows that battery charge is low.
How fast the batteries discharge depends on many circumstances, such as ambient temperature, condition of the surface of the road, tire pressure, weight of the driver, way of driving and utilisation of lighting, if fitted.
- Try to charge the batteries always before you reach the red LED range.
The last 3 LED (two red and one orange) mean a remaining capacity of about 15 %.
- Driving with flashing red LED's means an extreme stress for the battery and should be avoided under normal circumstances.

- When only one red LED is flashing, the Battery Safe feature is enabled. From this time, speed and acceleration is reduced drastically. It will allow you to move the mobility device slowly out of a dangerous situation before the electronic finally cuts off. This is deep discharging and should be avoided.
- Be aware that for temperatures below 20 °C, the nominal battery capacity starts to decline. For example, at -10 °C the capacity is reduced to about 50 % of the nominal battery capacity.
- To avoid damaging the batteries, never allow them to be fully discharged. Do not drive on heavily discharged batteries if it is not absolutely necessary, as this will strain the batteries unduly and shorten their life expectancy.
- The earlier you recharge the batteries, the longer they live.
- The depth of discharge affects the cycle life. The harder a battery has to work, the shorter is its life expectancy.

Examples:

- One deep discharge stresses the same as 6 normal cycles (green /orange display off).
- The battery life is about 300 cycles at 80 % discharge (first 7 LED off), or about 3000 cycles at 10 % discharge (one LED off).



The number of LED can vary depending on the remote type.

- Under normal operation, once a month the battery should be discharged until all green and orange LED are off. This should be done within one day. A 16 hour charge afterwards is necessary as reconditioning.

7.2.7 Transporting batteries

The batteries supplied with your mobility device are not hazardous goods. This classification is based on the German GGVS Hazardous Goods Road Transport Ordinances, and the IATA/DGR Hazardous

Goods Rail Transport / Air Transport Ordinances. Batteries may be transported without restrictions, whether by road, rail or by air. Individual transport companies have, however, guidelines which can possibly restrict or forbid certain transport procedures. Please ask the transport company regarding each individual case.

7.2.8 General instructions on handling the batteries

- Never mix and match different battery manufactures or technologies, or use batteries that do not have similar date codes.
- Never mix gel with AGM batteries.
- The batteries reach their end of life when the drive range is significantly smaller than usual. Contact your dealer or service technician for details.
- Always have your batteries installed by a properly trained mobility device technician or a person with adequate knowledge. They have the necessary training and tools to do the job safely and correctly.

7.2.9 How to handle damaged batteries correctly



CAUTION!
Corrosion and burns from acid leakage if batteries are damaged

- Remove clothes that have been soiled by acid immediately.

After contact with skin:

- Immediately wash affected area with lots of water.

After contact with eyes:

- Immediately rinse eyes under running water for several minutes; consult a physician.

- Always wear safety goggles and appropriate safety clothing when handling damaged batteries.
- Place damaged batteries in an acid-resistant receptacle immediately after removing them.
- Only ever transport damaged batteries in an appropriate acid-resistant receptacle.
- Wash all objects that have come into contact with acid with lots of water.

Disposing of dead or damaged batteries correctly

Dead or damaged batteries can be given back to your dealer or directly to Invacare.

7.2.10 Removing the batteries



CAUTION!

Risk of fire and burns if battery poles are bridged

- When replacing the batteries the battery poles **MUST NOT** come into contact with metal parts of the wheelchair causing bridging.
- Be sure to replace the battery pole caps after the batteries have been replaced.



CAUTION!

Risk of fire and burns due to damage to the battery cables

- The battery cables and other cables are positioned in a cable duct above the batteries. The cable duct protects the cables against crushing and other damage. It may not be removed.



Tools:

- 11 mm jaw spanner
- Slotted screwdriver

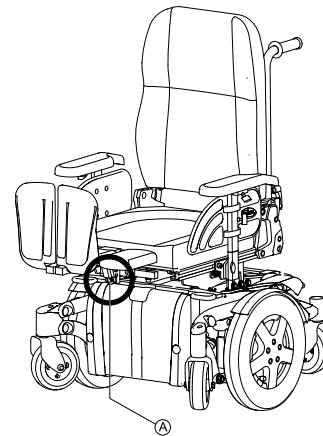

1.

Remove the side-mounted legrests if fitted. A centrally-fitted, manually adjustable legrest should be put in its top position by turning the spindle (A).

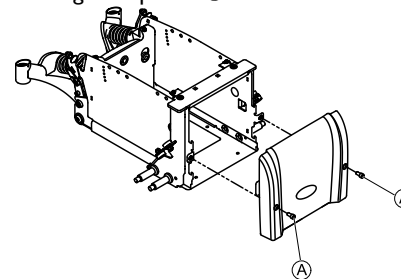

2.

Remove the thumb screws securing the front shroud/battery retention bracket to the wheelchair (A).

3.

Lift up to unhook the battery retention bracket from the wheelchair frame and remove the front shroud/battery retention bracket from the wheelchair.

4.



CAUTION!
Risk of crushing

The seat can fall down a few centimeters when removing the actuator without securing the seat.
 – Hold the seat in position while removing the actuator and then lower it carefully.

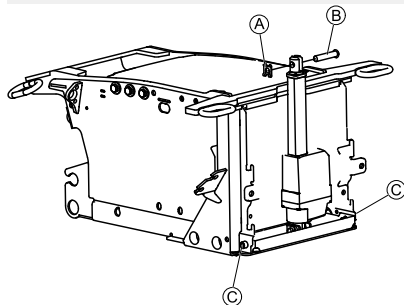

Only if a simple tilt is installed:

- a. Remove the SL retainer **A** with a slotted screwdriver and remove the bolt **B**.
- b. Remove the Allen screws **C**.

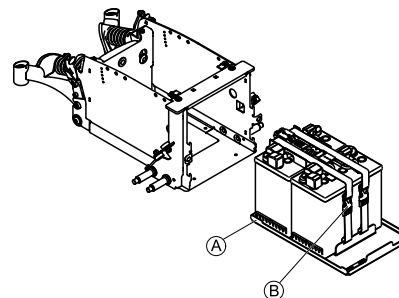

- 5.
6. Slide out the battery tray **A** with the batteries.
7. Disconnect the battery straps **B**.



7. Remove the terminal cover from the battery terminals (1).
8. First undo the bolt on the negative terminal (black cable) with the 11 mm jaw spanner.
9. After this, undo the bolt on the positive terminal (red cable).



CAUTION!
Risk of crushing

– The batteries are extremely heavy. Please ensure that they do not fall to the ground when they are removed from the chassis.

10. Installation takes place in reverse order.
11. Check all vehicle functions.
12. Check the new battery status and charge completely.

8 Transport

8.1 Transport — General information



CAUTION!

Injury hazard or material damage if a mobility device which is fitted with a table is transported in a vehicle

- If a table is fitted, always remove it before transporting the mobility device.



8.2 Transferring the mobility device to a vehicle



WARNING!

The mobility device is in danger of tipping over if it is transferred to a vehicle while the driver is still seated in the mobility device

- Transfer the mobility device without the driver whenever possible.
- If the mobility device with the driver has to be transferred to a vehicle using a ramp, ensure that the ramp does not exceed the maximum safe slope (refer to 11 Technical data, page 96).
- If the mobility device has to be transferred to a vehicle using a ramp that does exceed the maximum safe slope (refer to 11 Technical data, page 96), a winch must then be used. An attendant can then safely monitor and assist the transfer process.
- Alternatively, a platform lift may be used.
- Ensure that the total weight of the mobility device including the user does not exceed the maximum permitted total weight for the ramp or platform lift.
- The mobility device should always be transferred to a vehicle with the backrest in an upright position, the seat lifter lowered and the seat tilt in the upright position (refer to 6.6 Driving up and down gradients, page 74).



WARNING!

Risk of injury and damage to the mobility device

If the mobility device is to be transferred to a vehicle via a lift, when the remote is turned on, there is a risk that the device may act erratically and fall off the lift.

- Before transferring the mobility device via a lift, turn off the product and disconnect either the bus cable from the remote or the batteries from the system.

1. Drive or push your mobility device into the transport vehicle using a suitable ramp.

8.3 Use of the mobility device as a seat in a vehicle



The following section does not apply to models or configurations which may not be used as a vehicle seat. These are identified by the following labels on the lashing eyes and the identification label sticker:



WARNING!

Risk of death or serious injury

If a mobility device is secured using a 4-point tie-down system available from a third party supplier and the curb weight of the mobility device exceeds the maximum weight for the system, death or serious injury to the user and potential nearby occupant.

- The actual weight of this mobility device can exceed 140 kg. A suitably strong and proven 4-point tie-down system is available from Unwin Safety Systems. Contact Unwin for more information on how to obtain such a system in your country.

Unwin Safety Systems

Phone: + 44 (0)1935 827740

Email: sales@unwin-safety.co.uk

Web: www.unwin-safety.com

- If compatible, use the Docking Station system (available separately) as an alternative way to safely use this wheelchair as a vehicle seat. Contact Invacare for more details.



WARNING!

Risk of injury

Safety restraint devices must only be used when the wheelchair user's weight is 22 kg or more.

- When the user weight is lower than 22 kg, do not use the wheelchair as a seat in a vehicle.

**CAUTION!**

There is a risk of injury if the mobility device is not properly secured during use as a vehicle seat.

- If possible, the user should always leave the mobility device to use a vehicle seat and the safety belts provided with the vehicle.
- The mobility device should always be anchored facing in the transport vehicle's intended direction of travel.
- The mobility device must always be secured in accordance with the mobility device and anchoring system manufacturers' user manual.
- Always remove and secure any accessory parts fixed to the mobility device such as chin controls or tables.
- If your mobility device is fitted with an angle adjustable backrest, then it must be placed in an upright position.
- Fully lower elevated legrests, if fitted.
- Fully lower the seat lifter, if fitted.

**CAUTION!**

Risk of injury exists if a mobility device that is not fitted with leak-proof batteries is transported in a vehicle.

- Only ever use leak-proof batteries.

**CAUTION!**

Risk of injury or damage to the mobility device or to the transporting vehicle, if the legrests are in a raised position while the mobility device is used as a vehicle seat.

- Always completely lower height-adjustable legrests, if fitted.



Risk of damage to the headrest when using a Modulite seat and securing the mobility device with the Docking Station system

If you secure the mobility device with the Docking Station system and use a Modulite seat and the headrest is not set to the lowest possible position, the headrest might come loose during an accident.

- Always set the height of the headrest to the lowest possible position. Refer to 5.7.2 Adjusting the height of the headrest or neckrest, page 47.
- Next, the headrest must be adjusted to the user's ear height. Refer to 5.7.1 Adjusting the position of the headrest or neckrest, page 47.



In order to use a mobility device as a motor vehicle seat, it needs to be fitted with attachment points to enable anchoring in the motor vehicle. These accessories may be included in the standard scope of mobility device order and delivery in some countries (UK for example), but may also be obtained from Invacare as an option in other countries.

This mobility device complies with the requirements of ISO 7176-19 and may be used as a vehicle seat in connection with an anchoring system that has been checked and approved in accordance with ISO 10542. The transporting vehicle must be professionally converted to anchor the mobility device. Contact your vehicle's manufacturer for more information.

The mobility device has undergone a crash test in which it was anchored in the transporting vehicle's direction of travel. Other configurations were not tested. The crash test dummy was secured using pelvic and upper body safety belts. Both types of safety belt should be used in order to minimize the risk of injuries to head or upper body.

It is imperative that the mobility device is inspected by an authorized dealer before being used again after being involved in a crash. Alterations to the mobility device anchoring points may not be carried out without the manufacturer's permission.

8.3.1 How the mobility device is anchored in a vehicle

The mobility device is fitted with four anchoring points, which are labelled with the symbol shown on the right. Snap hooks or belt loops can be used for fixation.

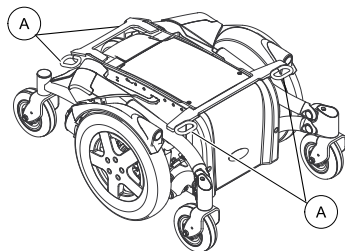

1. Secure the mobility device at the front and at the rear (A) with the anchoring system belts.
2. Secure the mobility device by tensioning the belts in accordance with the anchoring system manufacturer's user manual.

8.3.2 How the user is secured within the wheelchair



CAUTION!

There is a risk of injury if the user is not properly secured within the mobility device

- Even if the mobility device is fitted with a postural belt, this is no substitute for a proper safety belt which complies with ISO 10542 in the transport vehicle. Always use the safety belt installed in the transport vehicle.
- Safety belts must be in contact with the user's body. They must not be held at a distance from the user's body using parts of the mobility device such as armrests or wheels.
- Safety belts must be pulled as tightly as possible without causing the user discomfort.
- Safety belts must not be positioned while twisted.
- Ensure that the third seat belt anchorage point is not fixed directly to the vehicle floor, but to one of the vehicle uprights.



CAUTION!

Injury hazard during use of the mobility device as a vehicle seat if a headrest is wrongly adjusted or not installed

- This can cause the neck to be hyperextended during collisions.
- A headrest must be installed. The headrest optionally supplied for this mobility device by Invacare is perfectly suitable for use during transport.
 - The headrest must be adjusted to the user's ear height.

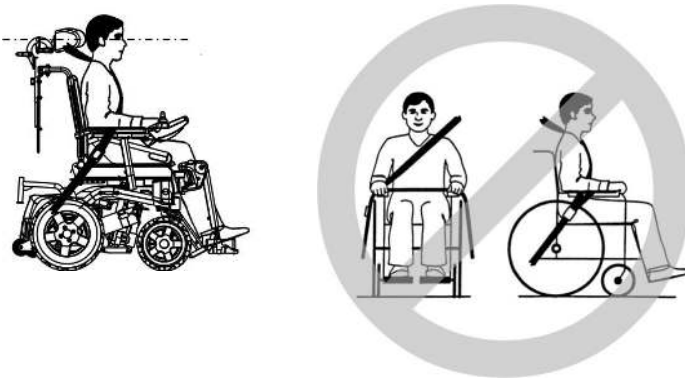

Seat belts may not be held at a distance from the user's body using parts of the wheelchair such as armrests or wheels.

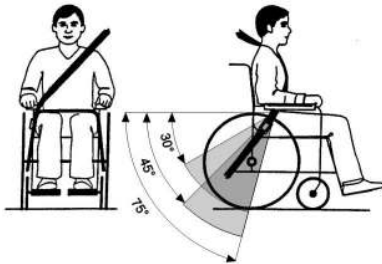

The pelvic belt should be positioned in the area between the user's pelvis and thighs so that it is unobstructed and not too loose. The ideal angle of the pelvic belt to the horizontal is between 45° and 75°.

The maximum permissible angle is between 30° and 75°. The angle should never be less than 30°!

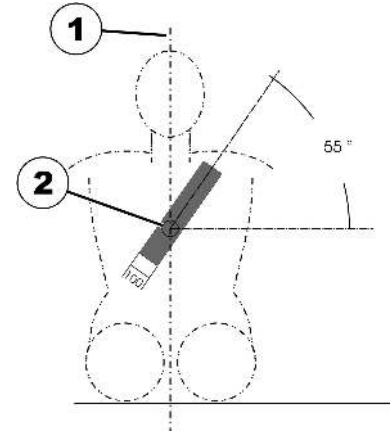

The safety belt installed in the transporting vehicle should be applied as shown in the illustration above.

- 1) Center line of the body
- 2) Center of the sternum

8.4 Transporting the mobility device without occupant



CAUTION! **Risk of injury**

- If you are unable to fasten your mobility device securely in a transport vehicle, Invacare recommends that you do not transport it.

Your mobility device may be transported without restrictions, whether by road, rail or by air. Individual transport companies have, however, guidelines which can possibly restrict or forbid certain transport procedures. Please ask the transport company regarding each individual case.

- Before transporting your mobility device, make sure the motors are engaged and that the remote is switched off.
Invacare strongly recommends that you additionally disconnect or remove the batteries. Refer to Removing the batteries.
- Invacare strongly recommends securing the mobility device to the floor of the transporting vehicle.

9 Maintenance

9.1 Maintenance introduction

The term “Maintenance“ means any task performed to ensure that a medical device is in good working order and ready for use as intended. Maintenance encompasses different areas, such as everyday care and cleaning, inspection checks, repair tasks and refurbishment.



Have your vehicle checked once a year by an authorised Invacare dealer in order to maintain its driving safety and roadworthiness.

9.2 Cleaning the mobility device

When cleaning the mobility device, pay attention to the following points:

- Only use a damp cloth and gentle detergent.
- Do not use any abrasive or scouring agents.
- Do not subject the electronic components to any direct contact with water.
- Do not use any high-pressure cleaning devices.

Disinfection

Spray or wipe disinfection using a tested and recognised product is permitted. A list of the current permitted disinfectants is available from the Robert Koch Institute at <http://www.rki.de>.

9.3 Inspection checks

The following table lists inspection checks that should be performed by the user and their intervals. If the mobility device fails to pass one of the inspection checks, refer to the chapter indicated or contact your authorised Invacare dealer. A more comprehensive list of inspection checks and instructions for maintenance work can be

found in the service manual for this device, which can be obtained from Invacare. That manual, however, is intended to be used by trained and authorized service technicians, and describes tasks which are not intended to be performed by the user.

9.3.1 Before each use of the mobility device

Item	Inspection check	If inspection is not passed
Signal horn	Check for correct function.	Contact your dealer.
Lighting system	Check that all lights, such as turn indicators, head lamps and tail lights, are functioning correctly.	Contact your dealer.
Batteries	Make sure the batteries are charged. See the user manual provided with your remote for a description of the Battery Charge Indicator.	Charge the batteries (refer to 7.2.3 How to charge the batteries, page 77).

9.3.2 Weekly

Item	Inspection check	If inspection is not passed
Armrests /side parts	Check that armrests are firmly attached in their holders and do not wobble.	Tighten the screw or clamping lever that holds the armrest (see chapter 5 Adjusting the mobility device to the user's seating posture, page 27). Contact your dealer.
Tires (pneumatic)	Check that the tires are undamaged.	Contact your dealer.
	Check that the tires are inflated to the correct pressure.	Inflate the tire to the correct pressure (see chapter 11 Technical data, page 96). Repair the inner tube if you have a flat tire (see chapter 9.6 Repair Instructions, page 93) or contact your dealer to have it repaired.
Tires (puncture-proof)	Check that the tires are undamaged.	Contact your dealer.

9.3.4 Inspections performed

It is confirmed by stamp and signature that all jobs listed in the inspection schedule of the service and repair instructions have been properly performed. The list of the inspection jobs to be performed can be found in the service manual which is available through Invacare.

9.3.3 Monthly

Item	Inspection check	If inspection is not passed
All upholstered parts	Check for damage and wear.	Contact your dealer.
Removable legrests	Check whether the legrests can be fixed securely and whether the loosening mechanism is properly operable.	Contact your dealer.
	Check that all adjustment options function properly.	Contact your dealer.
Casters	Check that casters rotate and swivel freely.	Contact your dealer.
Drive wheels	Check that the drive wheels rotate without wobbling. It is easiest to have someone stand behind the mobility device and observe the drive wheels as you drive away from them to do this.	Contact your dealer.
Electronics and connectors	Check all cables for damage and all connecting plugs for snug fit.	Contact your dealer.

Delivery Inspection	1st Annual Inspection
Stamp of authorized dealer / Date / Signature	Stamp of authorized dealer / Date / Signature
2nd Annual Inspection	3rd Annual Inspection
Stamp of authorized dealer / Date / Signature	Stamp of authorized dealer / Date / Signature

4th Annual Inspection	5th Annual Inspection
Stamp of authorized dealer / Date / Signature	Stamp of authorized dealer / Date / Signature

9.4 Short-term storage

In case a serious fault is detected, a number of safety mechanisms are built into your mobility device and will protect it. The controller prevents your mobility device from driving.

When the mobility device is in such a condition and while waiting for repair:

1. Switch off power.
2. Disconnect the batteries.
Depending on the mobility device model, you can either remove the battery packs or disconnect the batteries from the power module. Refer to the corresponding chapter about disconnecting the batteries.
3. Contact your dealer.

9.5 Long-term storage

In case your mobility device is not used for a longer period of time, you need to prepare it for storage to ensure a longer life for your mobility device and batteries.

Storing mobility device and batteries

- We recommend to store the mobility device at a temperature of 15° C, avoid hot and cold extremes when storing to ensure a long service life of the product and batteries.
- The components are tested and approved for greater temperature ranges as detailed below:
 - Allowable temperature range to store the mobility device is -40° up to 65° C.
 - Allowable temperature range to store batteries is -25° up to 65° C.
- Even not being used, batteries discharge themselves. Best practice is to disconnect the battery supply from the power module if storing the mobility device longer than two weeks. Depending on the mobility device model, you can either remove the battery packs or disconnect the batteries from the power module. Refer to the corresponding chapter about disconnecting the batteries. If in doubt which cable to disconnect, contact your dealer.
- Batteries should always be fully charged before storing.

- If storing the mobility device longer than four weeks, check the batteries once a month and recharge as needed (before gauge reads half full) to avoid damage.
- Store in a dry, well-ventilated environment protected from outer influences.
- Slightly overinflate pneumatic tires.
- Position the mobility device on flooring that is not discolored by contact with tire rubber.

Preparing mobility device for use

- Re-connect the battery supply to the power module.
- The batteries must be charged before use.
- Have the mobility device checked by an authorized Invacare dealer.

9.6 Repair Instructions



Important information about maintenance work tools!

- Some maintenance work which is described in this manual and can be carried out by the user without problems require the correct tools for proper work. If you do not have the correct tool available we do not recommend that you try to carry out the relevant work. In this case, we urgently recommend that you contact an authorised specialist workshop.

The following are instructions on maintenance and repairs that can be performed by the user. For the specifications of spare parts please see II Technical data, page 96, or consult the service manual, available from Invacare (in this connection please see the addresses and phone numbers at the end of this user manual). In case you require assistance, please contact your Invacare dealer.



CAUTION!

Risk of damage or injury if the vehicle is accidentally set into motion during repairs

- Switch the power off (ON/OFF Button).
- Engage the motors.
- Secure the vehicle against rolling away by placing wedges under the wheels.



CAUTION!

Risk of hands and feet being crushed by the weight of the wheelchair

- Pay attention to your hands and feet.
- Use the correct lifting techniques.

9.6.1 Repairing tire punctures (wheel rim type 3.00-8")



CAUTION!

Risk of injury

If the wheel has been insufficiently tightened during assembly, it can become loosened during driving.

- When reassembling the drive wheels, tighten the Allen screws at a torque of 30 Nm.
- Secure all screws using a suitable blocker (e.g. Loctite 243).



Tools:

- Allen key 6 mm
- Torque spanner
- Repair kit for tire repair **or** a new inner tube
- Talcum powder
- Screw blocker Loctite (e.g. Loctite 243)

Removing the wheel



1. Block up the vehicle (place wooden blocks under frame).
2. Unscrew the screw (1).
3. Remove the wheel from the hub.



Re-assembly is done in reverse order. Ensure that the tire is replaced on the same side and in the same travel direction as it was previously mounted.

Repairing the flat tire



CAUTION! **Risk of explosion**

The wheel will explode if you do not let the air out of the tire before removing the wheel.
– Always let the air out of the tire before removing it (press in the pin in the middle of the valve).



1. Unscrew valve cap.
2. Depressurise tire completely by pressing in the pin in the valve.
3. Remove the 5 cylinder head screws (back of the wheel, 2)
4. Remove the rim halves from the tire.
5. Remove the inner tube from the tire.
6. Repair inner tube and replace, or insert new.



If the old inner tube is to be repaired and re-used, and has become wet during repair, you can make replacement easier by sprinkling the inner tube with a little talcum powder.

7. Insert the wheel rim halves from outside into the tire.
8. Pump a little air into the inner tube.
9. Reinsert the cylinder head screws and tighten to 10 Nm. Avoid crushing the inner tube!
10. Ensure that the tire outer is seated correctly.
11. Pump the tire up to the prescribed pressure.
12. Ensure that the tire outer is seated correctly again.
13. Screw the valve cap back on.
14. Refit the wheel.

10 After Use

10.1 Reconditioning

The product is suitable for reconditioning. Actions to be carried out:

- Cleaning and disinfection. Refer to 9 Maintenance, page 89.
- Inspection according to service plan. Consult service instructions, available from Invacare.
- Adaptation to the user. Refer to 5 Adjusting the mobility device to the user's seating posture, page 27.

10.2 Disposal

- The equipment wrapping is potentially recyclable.
- The metal parts are used for scrap metal recycling.
- The plastic parts are used for plastic recycling.
- Electric components and printed circuit boards are disposed of as electronic scrap.
- Exhausted or damaged batteries can be returned to your medical equipment supplier or Invacare.
- Disposal must be carried out in accordance with the respective national legal provisions.
- Ask your city or district council for details of the local waste management companies.

II Technical data

II.1 Technical specifications

The technical information provided hereafter applies to a standard configuration or represents maximum achievable values. These can change if accessories are added. The precise changes to these values are detailed in the sections for the respective accessories.



Note that in some cases the measured values may vary up to ± 10 mm.

Permissible operating and storage conditions	
Temperature range for operation according to ISO 7176-9:	<ul style="list-style-type: none"> -25° ... +50 °C
Recommended storage temperature:	<ul style="list-style-type: none"> 15 °C
Temperature range for storage according to ISO 7176-9:	<ul style="list-style-type: none"> -25° ... +65 °C with batteries -40° ... +65 °C without batteries

Electrical system	
Motors	<ul style="list-style-type: none"> 2 x 340 W
Batteries	<ul style="list-style-type: none"> 2 x 12 V/73.5 Ah (C20) leakproof/gel (TDX SP2) 2 x 12 V/60 Ah (C20) leakproof/gel (TDX SP2) 2 x 12 V/50 Ah (C20) leakproof/gel (TDX SP2 NB)
Main fuse	<ul style="list-style-type: none"> 80 A (TDX SP2) 125 A (TDX SP2 NB)
Degree of protection	IPX4 ¹

Charging device	
Output current	<ul style="list-style-type: none"> 8 A \pm 8 %
Output voltage	<ul style="list-style-type: none"> 24 V nominal (12 cells)

Drive wheel tires	
Tire type	<ul style="list-style-type: none"> • 3.00 - 8" puncture-proof, puncture-protected, pneumatic
Tire pressure	<p>The recommended maximum tire pressure in bar or kpa is marked on the side wall of the tire or the rim. If more than one value is listed, the lower one in the corresponding units applies.</p> <p>(Tolerance = -0.3 bar, 1 bar = 100 kpa)</p>
Caster tires	
Tire type	<ul style="list-style-type: none"> • 6 x 2" puncture-proof
Driving characteristics	
Speed	<ul style="list-style-type: none"> • 6 km/h (TDX SP2 and TDX SP2 NB) • 8 km/h (only TDX SP2) • 10 km/h (TDX SP2 and TDX SP2 NB)
Min. braking distance	<ul style="list-style-type: none"> • 1000 mm (6 km/h) • 1500 mm (8 km/h) • 2100 mm (10 km/h)
Max. safe slope ² :	
without lifter	<ul style="list-style-type: none"> • 9° (15.8 %) according to manufacturer's specifications with 180 kg payload, 4° seat angle, 20° backrest angle
with lifter (only TDX SP2)	<ul style="list-style-type: none"> • 6° (10.5 %) according to manufacturer's specifications with 160 kg payload, 4° seat angle, 20° backrest angle
Max. climbable obstacle height	<ul style="list-style-type: none"> • 75 mm
Turning diameter	<ul style="list-style-type: none"> • 1120 mm
Turning width	<ul style="list-style-type: none"> • 1085 mm

Driving characteristics	
Pivot width	<ul style="list-style-type: none"> • 1350 mm
Drive range in accordance with ISO 7176-4 ³	<ul style="list-style-type: none"> • up to 31 km (73.5 Ah batteries) • up to 22 km (60 Ah batteries) • up to 20 km (50 Ah batteries)

Dimensions according to ISO 7176-15	Seat type	
	Modulite	Max
Overall height (without seat angle adjustment or lifter)	<ul style="list-style-type: none"> • 1010 mm (single-part seat frame) • 1010 - 1140 mm (telescopic seat frame, moving the backrest plate) 	<ul style="list-style-type: none"> • 1100 mm • 1125 mm
Overall height (with seat angle adjustment or lifter)	<ul style="list-style-type: none"> • 1170 mm (telescopic seat frame, moving the backrest plate) 	<ul style="list-style-type: none"> • 1100 mm • 1125 mm
Max. total width	<ul style="list-style-type: none"> • 615 mm (chassis TDX SP2 NB)⁴ • 650 mm (chassis TDX SP2) • 675 mm (seat width 48) • 725 mm (seat width 53) 	<ul style="list-style-type: none"> • 855 mm (seat width 49) • 915 mm (seat width 55) • 975 mm (seat width 61)
Total length (incl. standard legrests)	<ul style="list-style-type: none"> • 1160 mm 	<ul style="list-style-type: none"> • 1240 mm
Total length (without standard legrests)	<ul style="list-style-type: none"> • 980 mm 	<ul style="list-style-type: none"> • 970 mm
Stowage length	<ul style="list-style-type: none"> • 900 – 1010 mm 	
Stowage width	<ul style="list-style-type: none"> • 630 – 745 mm 	
Stowage height	<ul style="list-style-type: none"> • 710 – 830 mm 	
Ground clearance	<ul style="list-style-type: none"> • 70 mm 	

Dimensions according to ISO 7176-15	Seat type	
	Modulite	Max
Seat height ⁵ (without seat angle adjustment or lifter)	<ul style="list-style-type: none"> • 450 mm • 475 mm 	<ul style="list-style-type: none"> • 470 mm • 495 mm
Seat height ⁵ (with seat angle adjustment)	<ul style="list-style-type: none"> • 450 mm (manual and 20° electrical adjustment) • 475 mm (20° electrical adjustment) 	<ul style="list-style-type: none"> • 470 mm • 495 mm
Seat height ⁵ (with lifter or 30° seat angle adjustment)	<ul style="list-style-type: none"> • 475 - 775 mm • 420 - 720 mm (TDX SP2 Low-Rider with 73.5 Ah batteries) • 403 - 703 mm (TDX SP2 Low-Rider with 60 Ah batteries) 	—
Seat width (armrest adjustment range in parentheses)	<ul style="list-style-type: none"> • 380 mm (380 - 430 mm⁶) • 430 mm (430 - 480 mm⁶) • 480 mm (480 - 530 mm⁶) • 530 mm (530 - 580 mm⁶) 	<ul style="list-style-type: none"> • 490 mm (490 - 590 mm) • 550 mm (550 - 650 mm) • 610 mm (610 - 710 mm)
Seat depth	<ul style="list-style-type: none"> • 410 - 560 mm 	<ul style="list-style-type: none"> • 560/600/630 mm
Backrest height ⁵	<ul style="list-style-type: none"> • 480/540 mm (sling back) • 560 - 660 mm (telescopic seat frame, moving the backrest plate) 	<ul style="list-style-type: none"> • 570 - 620 mm (seat width 49) • 630 - 680 mm (seat width 55/61)
Seat cushion thickness	<ul style="list-style-type: none"> • 50/75/100 mm 	<ul style="list-style-type: none"> • 100 mm
Backrest angle	<ul style="list-style-type: none"> • 90° ... 120° 	<ul style="list-style-type: none"> • 90° ... 115°

Dimensions according to ISO 7176-15	Seat type	
	Modulite	Max
Armrest height	Telescopic seat frame: <ul style="list-style-type: none"> • 245 - 310 mm (T-armrest) • 230 – 360 mm (flip-up armrest) • 230 – 300 / 300 – 360 mm (following armrest) Single-part seat frame: <ul style="list-style-type: none"> • 275 - 340 mm 	<ul style="list-style-type: none"> • 250-340 mm • 290-380 mm
Armrest depth ⁷	<ul style="list-style-type: none"> • max. 440 mm 	<ul style="list-style-type: none"> • max. 550 mm
Horizontal location of axle ⁸	<ul style="list-style-type: none"> • 220 – 120 mm 	<ul style="list-style-type: none"> • 350 – 280 mm
Seat angle, electrical adjustment (30°)	<ul style="list-style-type: none"> • 0° ... +30° 	—
Seat angle, electrical adjustment (20°)	<ul style="list-style-type: none"> • 0° ... +20° 	
Seat angle, manual adjustment	<ul style="list-style-type: none"> • 0° ... +8° 	

Footrests and legrests		
Vari F	Length	<ul style="list-style-type: none"> • 290 - 460 mm
	Angle	<ul style="list-style-type: none"> • 70° - 0°
Vari A	Length	<ul style="list-style-type: none"> • 290 - 460 mm
	Angle	<ul style="list-style-type: none"> • 70° – 0°
ADE (electric)	Length	<ul style="list-style-type: none"> • 290 - 460 mm
	Angle	<ul style="list-style-type: none"> • 80° – 0°

Footrests and legrests		
ADM (manual)	Length	• 290 - 460 mm
	Angle	• 80° – 0°
Center-mounted (manual)	Length	• 280 – 385 mm
	Angle	• 90° – 0°

Weight⁹	TDX SP2 NB	TDX SP2
Curb weight with fixed seat angle	• approx. 138 kg	• approx. 154 kg
Curb weight with 20° electrical seat angle adjustment	• approx. 145 kg	• approx. 164 kg
Curb weight with 30° electrical seat angle adjustment	• approx. 151 kg	• approx. 170 kg
Curb weight with lifter	• approx. 164 kg	• approx. 183 kg

Component weights	
73.5 Ah batteries	• approx. 24.5 kg per battery
60 Ah batteries	• approx. 20 kg per battery
50 Ah batteries	• approx. 16 kg per battery

Payload	
Max. payload ¹⁰	<ul style="list-style-type: none"> • 136 kg (TDX Sprint) • 136 kg (20° seat angle adjustment) • 150 kg (TDX SP2 NB standard user weight) • 150 kg (TDX SP2 10 km/h version) • 160 kg (TDX SP2 with lifter or 30° seat angle adjustment) • 180 kg (HD version) • 180 kg (TDX SP2 6 km/h and 8 km/h versions)

Axle loads	
Max. front axle load	• 106 kg
Max. rear axle load	• 97 kg
Max. centre axle load	• 217 kg

- 1 IPX4 classification means that the electrical system is protected against spray water.
- 2 Static stability downhill, uphill, and sideways according to ISO 7176-1 = 9° (15.8 %)
Dynamic stability uphill according to ISO 7176-2 = 6° (10.5 %)
- 3 Note: The drive range of a mobility device is strongly influenced by external factors, such as the speed setting of the wheelchair, the charging state of the batteries, surrounding temperature, local topography, road surface characteristics, tire pressure, weight of user, drive style and use of batteries for lighting, servos etc.
The specified values are theoretical maximum achievable values measured according to ISO 7176-4.
- 4 Measured with solid tires. Pneumatic tires can increase the max. total width.
- 5 Measured without seat cushion
- 6 Width adjustable for side panel adjustment
- 7 Distance between backrest reference plane and most forward part of armrest assembly
- 8 Horizontal distance of wheel axle from intersection of loaded seat and backrest reference planes
- 9 The actual curb weight depends on the fittings your mobility device has been supplied with. Every Invacare mobility device is weighed when leaving the works. Refer to the nameplate for the curb weight (including batteries) measured.
- 10 If two values are possible the lowest always applies.

Notes

Invacare Sales Companies

Australia:

Invacare Australia PTY. Ltd.
1 Lenton Place, North Rocks NSW
2151
Australia
Phone: 1800 460 460
Fax: 1800 814 367
orders@invacare.com.au
www.invacare.com.au

United Kingdom:

Invacare Limited
Pencoed Technology Park, Pencoed
Bridgend CF35 5AQ
Tel: (44) (0) 1656 776 222
Fax: (44) (0) 1656 776 220
uk@invacare.com
www.invacare.co.uk

Canada:

Invacare Canada LP
570 Matheson Blvd E. Unit 8
Mississauga Ontario
L4Z 4G4, Canada
Phone: (905) 890 8300
Fax: (905) 501 4336

Eastern Europe & Middle East:

Invacare GmbH, EDO
Kleiststraße 49
D-32457 Porta Westfalica
Tel: (49) (0)57 31 754 540
Fax: (49) (0)57 31 754 541
edo@invacare.com
www.invacare.eu.com

Ireland:

Invacare Ireland Ltd,
Unit 5 Seatown Business Campus
Seatown Road, Swords, County Dublin
Tel : (353) 1 810 7084
Fax: (353) 1 810 7085
ireland@invacare.com
www.invacare.ie

New Zealand:

Invacare New Zealand Ltd
4 Westfield Place, Mt Wellington 1060
New Zealand
Phone: 0800 468 222
Fax: 0800 807 788
sales@invacare.co.nz
www.invacare.co.nz



Manufacturer:

Invacare Deutschland GmbH
Kleiststraße 49
32457 Porta Westfalica

1578997-C 2015-10-01



Making Life's Experiences Possible™



Yes, you can.®