

Küschall® Compact



EN **Active wheelchair**
User Manual



This manual **MUST** be given to the user of the product.
BEFORE using this product, read this manual and save for future reference.

 **küschall®**
designed for life

©2013 Küschall AG

All rights reserved. Republication, duplication or modification in whole or in part is prohibited without prior written permission from Küschall AG. Trademarks are identified by ™ and ®. All trademarks are owned by or licensed to Küschall AG or its subsidiaries unless otherwise noted.

Contents

1	General	5		
1.1	Information about the User Manual	5		
1.2	Symbols	5		
1.3	Warranty.	6		
1.4	Intended use.	6		
1.5	Service life	6		
1.6	Copyright protection.	6		
2	Safety	7		
2.1	Safety information.	7		
2.2	Safety devices	7		
3	Components and their functions	8		
3.1	Overview	8		
3.2	Parking brakes.	9		
3.3	Backrest	10		
3.4	Hingedown back (optional)	10		
3.5	Push handles.	11		
3.6	Stabilizing bar for the back (optional)	12		
3.7	Siderest in the frame colour, height adjustable, foldable	13		
3.8	Siderest with locking mechanism, height adjustable, foldable	13		
3.9	Side rest, infinitely height adjustable	14		
3.10	Simple armrest, height-adjustable, swivelling	14		
3.11	Antitipper	15		
3.12	Swivelling leg rests	16		
3.13	Seat cushion	16		
4	Accessories	17		
4.1	Pelvic belt	17		
4.2	Tipper aid	17		
4.3	Air pump	18		
4.4	Passive illumination.	18		
4.5	Cane holder	18		
4.6	Transit wheels.	18		
4.7	Luggage carrier	19		
5	Setup	20		
5.1	Safety information.	20		
6	Using the wheelchair	21		
6.1	Safety information.	21		
6.2	Braking during use	21		
6.3	Getting in and out of the wheelchair	22		
6.4	Driving and steering the wheelchair.	23		
6.5	Negotiating steps and kerbs	24		
6.6	Going up and down stairs	26		
6.7	Negotiating ramps and slopes	26		
6.8	Stability and balance when seated	27		
7	Transport	29		
7.1	Safety information.	29		
7.2	Folding and unfolding the wheelchair	29		
7.3	Removing and fitting the rear wheels.	30		
7.4	Transporting the occupied wheelchair in a vehicle	31		
8	Maintenance	36		
8.1	Safety information.	36		
8.2	Maintenance Schedule	36		
8.3	Cleaning	38		
8.4	Disinfection.	38		
9	Troubleshooting	39		
9.1	Safety information.	39		
9.2	Identifying and repairing faults	40		

10	After Use	41
10.1	Re-use	41
10.2	Disposal	41
11	Technical data	42
11.1	Dimensions and weight	42
11.2	Environmental conditions	43
11.3	Tyres	43
11.4	Identification label	43

1 General

1.1 Information about the User Manual

Thank you for choosing a *küschall*® wheelchair.

This User Manual contains important information about using the wheelchair. In order to ensure safety when using your wheelchair, read the User Manual carefully and follow the safety information.

If your vision is impaired, you can view the user manual as a PDF file on the Internet at www.kueschall.com and enlarge it on-screen as required.

If you cannot enlarge the texts and graphics sufficiently, please contact the *küschall*® distributor for your country;

→ addresses on the reverse of this document. If necessary, we will provide you with a high resolution PDF file of the user manual.

Moreover, you can have the PDF file read out to you with the aid of suitable programs using special language functions on your computer (e.g. in Adobe®Reader®X: Shift+Ctrl+Y).

 The equipment of your wheelchair may differ from the descriptions and diagrams given here due to the wide range of models available.

If you need additional information, please refer to our website at www.kueschall.com.

1.2 Symbols

Symbols in this manual

In this User Manual warnings are indicated by symbols. The warning symbols are accompanied by a heading that indicates the severity of the danger.



WARNING!

Indicates a hazardous situation that could result in serious injury or death if it is not avoided.



CAUTION!

Indicates a hazardous situation that could result in minor or slight injury if it is not avoided.



IMPORTANT!

Indicates a hazardous situation that could result in damage to property if it is not avoided.



Gives useful tips, recommendations and information for efficient, trouble-free use.



This product complies with Directive 93/42/EEC concerning medical devices. The launch date of this product is stated in the CE declaration of conformity.

Symbols on the product



Snap hook symbol: Tie-down positions where the restraint system straps must be placed in case of transporting the occupied wheelchair in a vehicle.

Compact

1.3 Warranty

Küschall AG guarantees that their wheelchairs are free from defects and are fully functional. The warranty covers all faults and defects which are verifiably attributable to faulty construction, substandard materials or poor workmanship. Warranty claims against the manufacturer may only be made by the distributor and not by the user of the product.

The warranty does not cover normal wear and tear, the consequences of improper handling or damage, poor maintenance and incorrect assembly or commissioning by the purchaser or a third person or faults which are attributable to circumstances beyond our control. Wearing parts are not covered by the guarantee. The warranty is voided if modifications are made to the product which were not authorised and not performed by the specialist dealer or if inappropriate accessories or spare parts are used. The warranty does not cover consequential costs arising from the rectification of defects such as freight and travel expenses, labour costs, fees etc.

The term of the warranty is 24 months. The frame is guaranteed for 5 years.

Furthermore, the terms and conditions are part of the general terms and conditions particular to the individual countries in which the product is sold.

Quality and Flame Retardancy

Quality is fundamental to the company's operation, working within the disciplines of ISO 9001 and ISO 13485.

The wheelchair has been tested in accordance with EN 12183. It includes a test for flammability.

1.4 Intended use

The active wheelchair is propelled manually and should only be used for independent or assisted transport of a disabled person with mobility difficulties. When used without an assistant, it should only be used by persons who are physically and mentally able to use the wheelchair

safely (e.g. to propel themselves, steer, brake). The wheelchair should only be used on level ground and accessible terrain, as well as indoors. This active wheelchair needs to be subscribed and fit to your specific health condition.



WARNING!

Any other or incorrect use could lead to hazardous situations.

1.5 Service life

The expected service life is five years, presuming that the product is used daily and in accordance with safety instructions, maintenance instructions and intended use, stated in this manual.

1.6 Copyright protection

This User Manual is protected by copyright. It may not be reprinted or copied or transferred to third parties in part or in full without the prior written consent of the manufacturer.

2 Safety

2.1 Safety information

This section contains important safety information for the protection of the wheelchair user and assistant and for safe, trouble-free use of the wheelchair.



WARNING!

Risk of accidents and serious injury

Accidents with resulting serious injury can occur if the wheelchair is wrongly adjusted.

- Adjustments at the wheelchair always must be carried out by a specialist dealer.



WARNING!

Risk due to driving style being unsuitable for the conditions

There is a risk of skidding on wet ground, gravel or uneven terrain.

- Always adjust your speed and driving style to the conditions (weather, surface, individual ability, etc.).



WARNING!

Risk of injury

In a collision you could sustain injury to parts of your body that extend beyond the wheelchair (e.g. feet or hands).

- Avoid an unbraked collision.
- Never drive into an object head-on.
- Drive carefully through narrow passages.



WARNING!

Risk due to wheelchair being out of control

At high speed you could lose control of your wheelchair and overturn.

- Never exceed a speed of 7 km/h.
- Avoid collisions in general.



CAUTION!

Risk of burning

The wheelchair components can heat up when exposed to strong sunlight.



CAUTION!

Risk of getting fingers caught

There is always a risk of getting, e.g. fingers or arms, caught in the moving parts of the wheelchair.

- Make sure when activating the folding or insertion mechanisms of moving parts, such as the removable axle of the rear wheel, folding backrest or antitipper, that nothing becomes caught.

2.2 Safety devices



WARNING!

Risk of accidents

Safety devices that are incorrectly set or no longer working (brakes, antitipper) can cause accidents.

- Always check that the safety devices are working before you use the wheelchair and have them checked regularly by the specialist dealer.

The functions of the safety devices are described in chapter 3 Components and their functions, page 8 .

3 Components and their functions

3.1 Overview

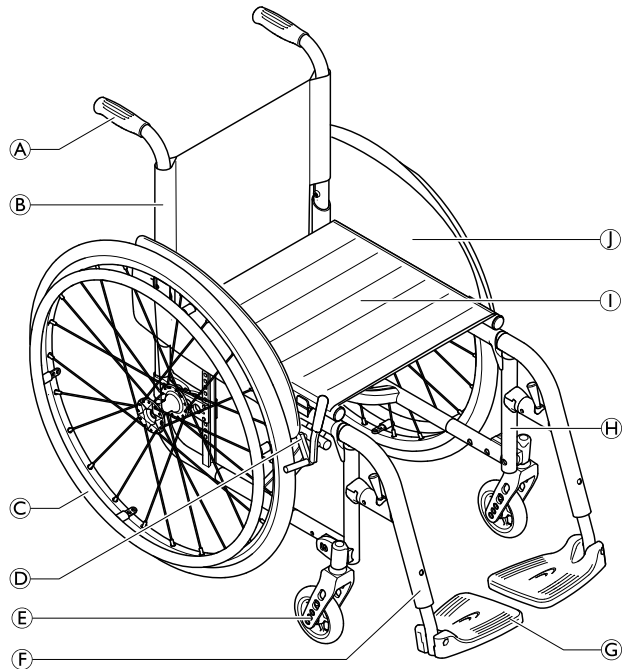

(A)	Push handle
(B)	Back
(C)	Rear wheel with handrim
(D)	Parking brake
(E)	Front wheel fork with front wheel
(F)	Leg rests, swivelling
(G)	Footrest
(H)	Frame
(I)	Seat
(J)	Clothes-guard

Short description

The *küschall Compact* is a folding active wheelchair with cross struts and swivelling leg rests.

i The equipment of your wheelchair may differ from the diagram as each wheelchair is manufactured individually to the specifications in the order.

3.2 Parking brakes

The parking brakes are used to immobilise the wheelchair when it is stationary to prevent it from rolling away.



WARNING!

Risk of overturning if you brake sharply

If you apply the parking brakes while you are moving, the direction of movement can become uncontrollable and the wheelchair may stop suddenly, which can lead to a collision or to you falling out.

- Never apply the parking brakes while you are moving.



WARNING!

Risk of overturning

The parking brakes will not operate correctly unless there is sufficient air in the tyres.

- Ensure the correct tyre pressure, 11.3 Tyres, page 43.

Standard brake

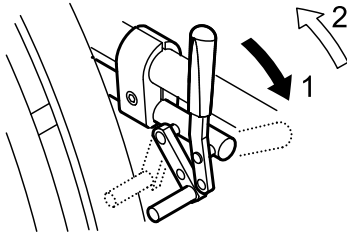

1. To apply the brake, push the brake lever forwards as far as possible.
2. To release the brake, pull the brake lever backwards.

Pull brake

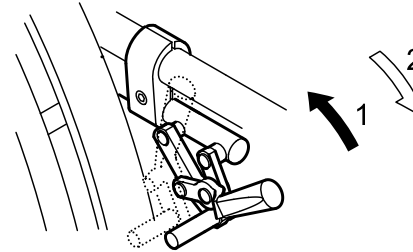

1. To apply the brake, pull the brake lever backwards as far as possible.
2. To release the brake, push the brake lever forwards.

Performance brake

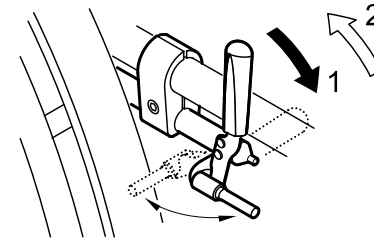

1. To apply the brake, push the brake lever forwards as far as possible.
2. To release the brake, pull the brake lever backwards.

Active brake

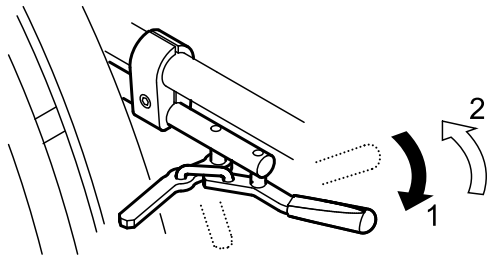

1. To apply the brake, pull the brake lever forwards beside or between your knees as far as possible.
2. To release the brake, push the brake lever backwards beside or between your knees.

3.3 Backrest

Backrest cover

You can adjust the tension of the backrest cover as required.

Adjusting the backrest cover

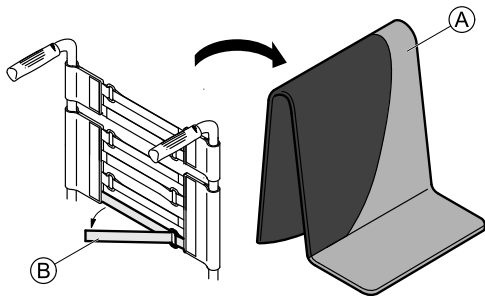

1. Remove the backrest cushion (A).
2. Loosen the Velcro® tapes (B) on the rear of the backrest cover by simply pulling on them.
3. Tighten or loosen the tapes as required then reattach them.



WARNING! **Risk of tipping**

If the bands are set very loose, the tipping point of your wheelchair is changed for the worse.
– Ensure that the bands are set correctly.



IMPORTANT!

– Do not overtighten the bands; this is to ensure that the geometry of the wheelchair is not changed.



IMPORTANT!

– Only ever tighten the bands when the wheelchair is unfolded.

3.4 Hinged down back (optional)

The back can be hinged down and straightened up in both the folded and unfolded state.

Hinging down the back

1. To hinge down the back, grip the strap on the back of the wheelchair and pull it upwards.
2. At the same time, push the upper edge of the back forwards.

Straightening up the back

1. To straighten up the back, grip the upper edge of the back and fold it upwards.

**IMPORTANT!**

- Do not fold and unfold the wheelchair when the back is hinged down.

3.5 Push handles**IMPORTANT!**

- Always check the push handles before using the wheelchair, as to whether the hand grips are secure, cannot be turned and cannot be pulled off.

Foldable push handles (optional)

Foldable push handles are used when the push handles are only required occasionally.

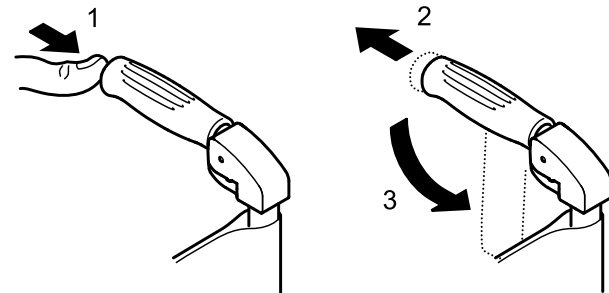

1. To fold down the push handles, hold the wheelchair with one hand. Grip the push handle with the other and using your thumb activate the release (1) that is concealed under the plastic.
2. At the same time pull the push handle backwards (2) and fold it down (3).
3. To fold the push handles up, bring the push handle into the horizontal position until it engages.



IMPORTANT!

- Make sure that the push handle does actually engage so that it does not accidentally fold down while pushing the wheelchair.

Height adjustable, angled push handles (optional)

The infinitely height adjustable push handles allow any assistant to adjust the handles to a comfortable level.

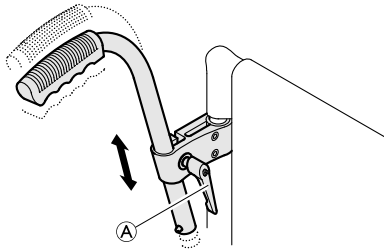

1. To set the height of the push handles, loosen the bolt Ⓐ, push the handle to the desired position and tighten the bolt again.

3.6 Stabilizing bar for the back (optional)

An optional stabilizing bar is available to increase the rigidity of the backrest on wheelchairs with large back heights or widths.



IMPORTANT!

- Do not use the stabilizing bar to lift or push the wheelchair. It could break.
- Release the stabilizing bar before folding the wheelchair.

Releasing the stabilizing bar

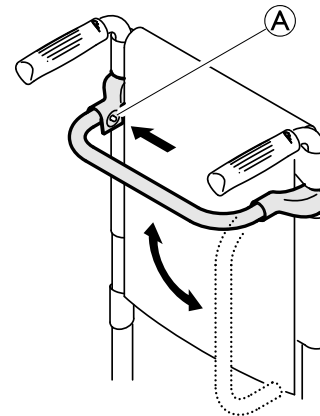

1. Push the spring pin Ⓐ on the fastening on the left-hand side and swivel the stabilizing bar downwards.

The stabilizing bar can also be completely removed, by pushing the spring pins on both sides. The stabilizing bar can then be taken off.

3.7 Siderest in the frame colour, height adjustable, foldable

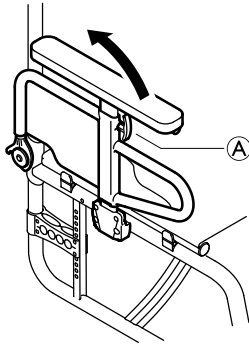

Folding

1. Grip the siderest by the cushion or by the front curve and fold it back.

Removing

1. Fold the siderest back and pull it up out of the holder on the back.

Fitting

1. Insert the siderest from above into the holder on the back.
2. Fold it downwards.

Adjusting the height

1. Tip the lever **A** on the front of the support and move the armrest upwards or downwards until you reach the desired height.
2. Engage the lever.
3. Perform the setting on both sides.



CAUTION!

This siderest does not engage into the wheelchair.
– Therefore do not hold it in order to lift the wheelchair.

3.8 Siderest with locking mechanism, height adjustable, foldable

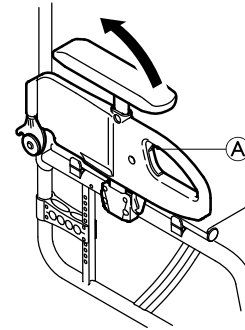

Folding

1. Push the grey grip **A** and fold the siderest back.

Removing

1. Fold the siderest back and pull it up out of the holder on the back.

Fitting

1. Insert the siderest from above into the holder on the back.
2. Fold it downwards.

Adjusting the height

1. Release the bolt in the middle of the seat back using a spanner.
2. Move the armrest upwards or downwards until you reach the desired height.

Compact

3. Tighten the screw.
4. Perform the setting on both sides.

3.9 Side rest, infinitely height adjustable

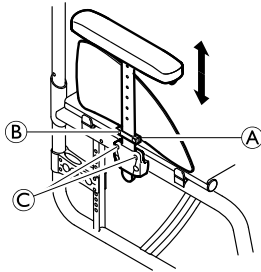

Removing

1. Pull the side rest by the arm cushion out of the holder.
2. To adjust how easy or difficult it is to pull the side rest out of the holder, change the degree to which the screws © are tightened.

Fitting

1. Push the side rest into the holder.

Adjusting the height

1. Loosen the screw ② of the retaining plate ①.
2. Move the armrest upwards or downwards until you reach the desired height.
3. Tighten the screw ②.
4. Perform the setting on both sides.

3.10 Simple armrest, height-adjustable, swivelling

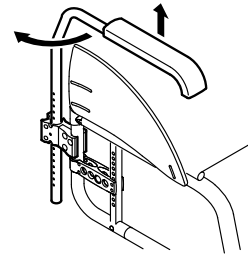

Removing

1. Raise the armrest and pull it upwards out of the holder.

Fitting

1. Push the armrest into the holder.

Adjusting the height

1. Pull the armrest out of the holder.
2. Loosen the screw on the tube of the armrest and screw it back in at the desired height.
3. Push the armrest back into the holder.
4. Perform the setting on both sides.

Swivelling

1. Raise the armrest a little and swivel it outwards.

3.11 Antitipper

An antitipper prevents the wheelchair from tipping backwards.



WARNING!

Risk of overturning

Antitippers that are incorrectly set or no longer working can lead to overturning.

- Always check that the antitipper is working before using the wheelchair and have it set or readjusted by a specialist dealer when required.



WARNING!

Risk of overturning

On uneven or soft ground, the antitipper can sink into potholes or directly into the ground, thereby curtailing or eliminating its safety function.

- Only use the antitipper when travelling on even and firm ground.

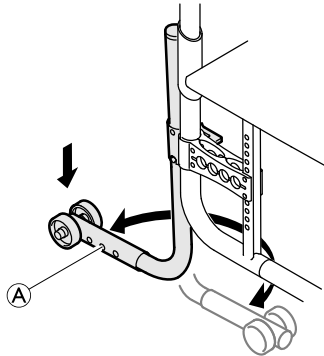

Activating the antitipper

1. Push the antitipper downwards and swivel it backwards until it engages.



WARNING!

Risk of tipping

An activated antitipper can catch when negotiating a step or an edge.

- Always deactivate the antitipper before driving over a step or kerb.

Deactivating the antitipper

1. Push the antitipper downwards and swivel it forwards until it engages.

Setting the height

1. Press the spring pin (A) on the antitipper and push the outer section to the position required. Allow the spring pin to engage in the nearest hole.

3.12 Swivelling leg rests

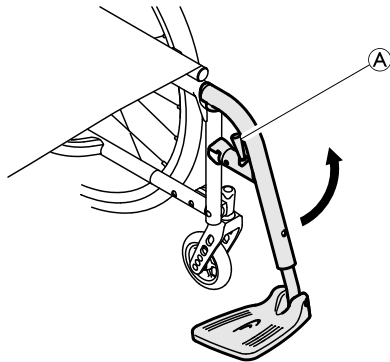

i Use an antislip underlay or Velcro® fastening tapes to avoid slipping of the seat cushion.

Swivelling

1. Activate the release lever **A** and swivel the leg rests to the outside.

Swivelling forwards

1. Swivel the leg rest forwards until it engages.

Unhinging

1. Activate the release lever **A**.
2. Pull the leg rest upwards.

Hinging

1. Hinge the leg rest on the front of the frame and swivel it forwards until it engages.

3.13 Seat cushion

A suitable cushion is needed to provide an even pressure distribution on the seat.

4 Accessories

4.1 Pelvic belt

Your wheelchair can be fitted with a pelvic belt which will prevent you from sliding forward in the wheelchair or from falling out of the wheelchair.

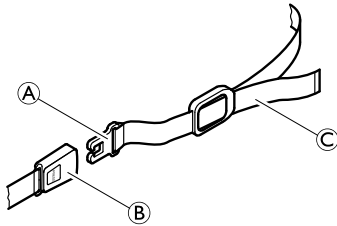

WARNING!

Risk of serious injuries through strangulation.

- Ensure that you are sitting fully back in the seat and that the pelvis is as upright and symmetrical as possible - not forward on one side or tilted back.
- Position the lap belt so that the hip bones can be felt above the belt.
- Adjust the length using the buckles so that there is just sufficient room for your hand to slide between your body and the belt. It is recommended that the clasp is kept in a central position, i.e. make adjustments to each side.
- Make sure that the belt cannot slide and the clasp does not dissolve. Refit the pelvic belt if necessary, → specialist dealer.
- Check and possibly change these adjustments each time the belt is used.

Fitting the pelvic belt

1. Remove the backrest cover and attach the Velcro® fastener to the backrest at the required height. Ensure that the fastener is at the front.

Opening the pelvic belt

1. Push in the PRESS button and pull the catch Ⓐ out of the buckle Ⓑ. The pelvic belt opens.

Closing the pelvic belt

1. Push the catch Ⓐ into the buckle Ⓑ.
2. Pull the belt Ⓒ until you are held securely in the wheelchair.

4.2 Tipper aid

With the tipper aid, an assistant can tip the wheelchair more easily, in order to navigate steps for example.

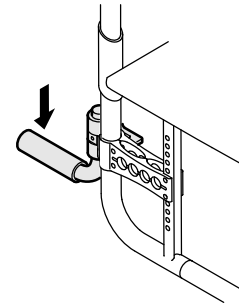

WARNING!

Risk of overturning

- Ensure that the tipper aid does not project beyond the external diameter of the rear wheel.

Compact

1. Hold the wheelchair by the push handles.
2. Press the tipper aid with your foot and hold the wheelchair in the tipped position until you have overcome the obstacle.

4.3 Air pump

The air pump is fitted with a universal valve connection.

1. Remove the dust cap from the valve connection.
2. Push the valve connection onto the open valve on the wheel and pump the wheel up.

4.4 Passive illumination

You can attach reflectors to the rear wheels.

4.5 Cane holder

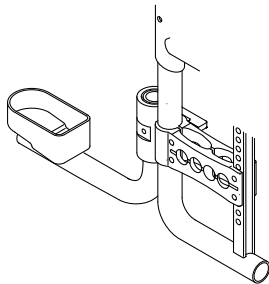

WARNING!

Risk of overturning

– Ensure that the cane holder does not project beyond the external diameter of the rear wheel.

1. Place the cane in the holder.
2. Fix the top of the cane to the backrest.

4.6 Transit wheels

If your wheelchair is too wide for certain applications, e.g. trains/aeroplanes, narrow passageways, narrow doors, the transit wheels can be used.



WARNING!

– When using transit wheels, the parking brakes no longer have any effect and you cannot control your wheelchair via the handrims.

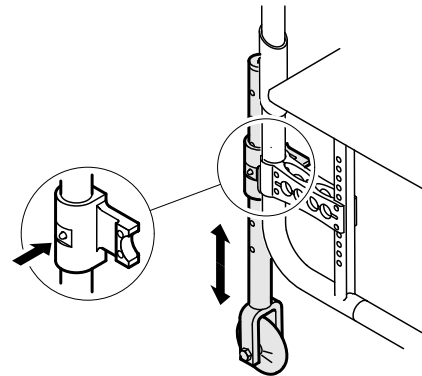

Switching to transit wheels

1. Lower the transit wheels into the operating position. To do this, press the pin inwards until you can pull the tube down.
2. Press the second pin in.
3. Pull the tube further downwards until the pin engages into the slot.
4. Move the wheelchair to a stable object (door frame, heavy table), which you can use for support and hold onto it firmly with one hand.

5. Tilt the wheelchair until the rear wheel on the opposite side rises off the floor.



Prior to removing the rear wheels, the distance between the lowered transit wheels and the floor should not be more than 2 cm.

6. Remove the rear wheel,
→ 7.3 Removing and fitting the rear wheels, page 30.
7. Repeat the process on the other side.

Switching from transit wheels to rear wheels

1. Move the wheelchair to a stable object, which you can use for support and hold onto it firmly with one hand.
2. Tilt the wheelchair until the transit wheel on the opposite side rises slightly off the floor.
3. Fit the rear wheel back onto the removable axle,
→ 7.3 Removing and fitting the rear wheels, page 30.
4. Bring the transit wheels back into the inactive position.
5. Repeat the process on the other side.

4.7 Luggage carrier

Your wheelchair can be fitted with a luggage carrier. When not in use, the luggage carrier can be folded up.



WARNING! Risk of tipping

Weight on the carrier changes the tipping behaviour of the wheelchair. The wheelchair can tip forwards more easily when the luggage carrier is loaded.

- Use the luggage carrier only for transporting small and lightweight luggage.
- Avoid driving the wheelchair to fast when carrying luggage.
- Avoid driving ramps and slopes when carrying luggage.
- Do not stand on the luggage carrier.

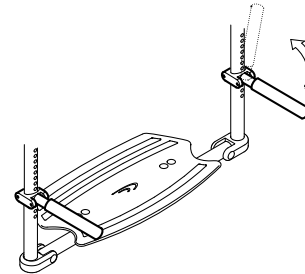

5 Setup

5.1 Safety information



CAUTION!

Risk of injury

- Before using the wheelchair, check its general condition and its main functions, 8.2 Maintenance Schedule, page 36 .

Your specialist dealer will supply your wheelchair ready for use. Your dealer will explain the main functions and ensure that the wheelchair meets your needs and requirements.

Adjustments of the axle position and the front wheel supporters must be carried out by a specialist dealer.

If you receive your wheelchair folded, please read section 7.2 Folding and unfolding the wheelchair, page 29.

6 Using the wheelchair

6.1 Safety information



WARNING!

Risk of accidents

Uneven tyre pressure can have a huge effect on handling.

- Check the tyre pressure before each journey.



CAUTION!

Risk of crushing

There may be a very small gap between the rear wheel and the mudguard with the risk that you could trap your fingers.

- Ensure that you always propel your wheelchair using the handrims only.



CAUTION!

Risk of crushing

There may be a very small gap between the rear wheel and the parking brake with the risk that you could trap your fingers.

- Ensure that you always propel your wheelchair using the handrims only.

6.2 Braking during use

Whilst you are moving, you brake by transferring force to the handrim with your hands.



WARNING!

Risk of overturning

If you apply the parking brakes while you are moving, the direction of movement can become uncontrollable and the wheelchair may stop suddenly, which can lead to a collision or to you falling out.

- Never apply the parking brakes while you are moving.



WARNING!

Risk of falling out of the wheelchair

If the wheelchair is rapidly decelerated by an assistant pulling at the push handles, the user may fall out of the wheelchair.

- Always apply the pelvic belt if present.
- Make sure your assistant has been trained individually in transferring occupied wheelchairs.



CAUTION!

Risk of burning your hands

If you brake for a long time, a lot of frictional heat is produced at the handrims (especially MaxGrepp and Supergripp).

- Wear suitable gloves.

1. Hold the handrims and press evenly with both hands until the wheelchair stops.

Braking with an assistant

With an assistant's brake (drum brake) an assistant can brake the wheelchair while it is moving. The assistant's brake can also be used as a parking brake.

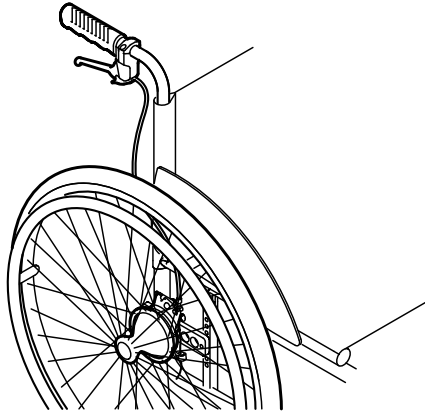

1. To brake, pull the brake lever on the push handle.
2. To park, pull the brake lever firmly until the safety lever engages.
3. To release, pull the brake lever and release the safety lever underneath the brake lever.

6.3 Getting in and out of the wheelchair



WARNING!

Risk of overturning

There is a high risk of overturning during the transfer.
– Only get in and out without assistance if you are physically able to do so.



WARNING!

Risk of overturning

The wheelchair could tip forwards if you stand on the footrest.

- Never stand on the footrest when getting in and out.



CAUTION!

If you release or damage the brakes the wheelchair could roll away out of control.

- Do not support yourself on the brakes when getting in and out.



IMPORTANT!

The mudguards and armrests could become damaged.

- Never sit on the mudguards or armrests when getting in and out.

1. Apply the parking brakes.
2. Place your feet on the ground.
3. Hold the wheelchair and, if necessary, also hold a fixed object in the vicinity.
4. Move slowly to chair.

6.4 Driving and steering the wheelchair

You drive and steer the wheelchair using the handrims. Before driving without an assistant you must find your wheelchair's tipping point.



WARNING!

Risk of tipping

The wheelchair can tip backwards if it is not fitted with an antitipper. When finding the tipping point, an assistant must stand immediately behind the wheelchair to catch it if it tips over.

- To prevent tipping, install an antitipper device.



WARNING!

Risk of tipping

The wheelchair can tip forwards.

- When setting up your wheelchair, test its behaviour in terms of tipping forward and adjust your driving style accordingly.



CAUTION!

A heavy load hanging on the backrest can affect the wheelchair's centre of gravity.

- Change your driving style accordingly.

Finding the tipping point

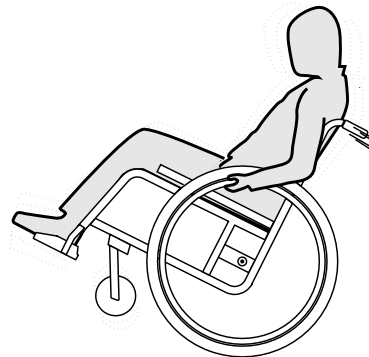

1. Release the brake.
2. Roll forwards a short distance, grasp both handrims firmly and pull backwards with a slight kick.
3. The shift in weight and steering in opposite directions with the handrims will enable you to identify the tipping point.

6.5 Negotiating steps and kerbs



WARNING!

Risk of overturning

When negotiating steps you could lose your balance and tip the wheelchair over.

- Always approach steps and kerbs slowly and carefully.
- Do not go up or down steps that are higher than 25 cm.



CAUTION!

An activated antitipper prevents the wheelchair from tipping backwards.

- Deactivate the antitipper before going up or down steps or kerbs.

With an assistant



Going down a step

1. Move the wheelchair right up to the kerb and hold the handrims.
2. The assistant should hold both push handles, place one foot on the tipper aid (if installed) and tilt the wheelchair backwards so that the front wheels lift off the ground.
3. The assistant should then hold the wheelchair in this position, push it carefully down the step and then tilt it forwards until the front wheels are back on the ground.

Going up a step**WARNING!****Risk of serious injuries**

Going up steps and kerbs frequently can result in earlier than expected fatigue break of the wheelchair backrest. The user might fall out of the wheelchair.

- Always use a tipper aid when going up steps or kerbs.

1. Move the wheelchair backwards until the rear wheels touch the kerb.
2. The assistant should tilt the wheelchair using both push handles so that the front wheels lift off the ground, then pull the rear wheels over the kerb until the front wheels can be placed back on the ground.

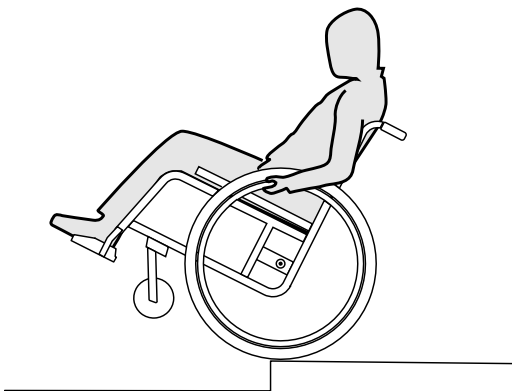
Without an assistant**WARNING!****Risk of tipping**

When going down a step without an assistant you could tip over backwards if you cannot control your wheelchair.

- First learn how to go down a step with an assistant.
- Learn how to balance on the rear wheels, 6.4 Driving and steering the wheelchair, page 23.

Going down a step

1. Move the wheelchair right to the kerb, lift the front wheels and keep the wheelchair balanced.
2. Now slowly roll both rear wheels over the kerb. While doing this, hold the handrims firmly with both hands until the front wheels are back on the ground.

6.6 Going up and down stairs



WARNING!

Risk of overturning

When negotiating stairs you could lose your balance and overturn your wheelchair.

- Always use two assistants when negotiating stairs with more than one step.



1. You can go up and down stairs by taking them one step at a time, as described above. The first assistant should stand behind the wheelchair holding the push handles. The second assistant should hold a solid part of the front frame to steady the wheelchair from the front.

6.7 Negotiating ramps and slopes



WARNING!

Risk due to wheelchair being out of control

When negotiating slopes or gradients your wheelchair could tip backwards, forwards or sideways.

- Always have an assistant behind the wheelchair when approaching long slopes.
- Avoid lateral slopes.
- Avoid slopes of more than 7°.
- Avoid jerking when changing direction on a slope.



CAUTION!

Your wheelchair could run away even on slightly sloping ground if you do not control it using the handrims.

- Use the parking brakes if your wheelchair is stationary on sloping ground.

Going up slopes

To go up a slope, you must create some momentum, keep up the momentum and control the direction at the same time.

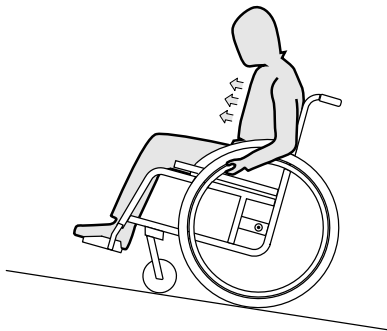

1. Bend your upper body forwards and propel the wheelchair with quick, powerful strokes on both handrims.

Going down slopes

When going down slopes, it is important to control your direction and particularly your speed.

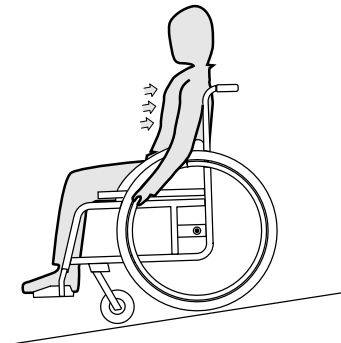

1. Lean back and carefully allow the handrims to run through your hands. You should be able to stop the wheelchair at any time by gripping the handrims.



CAUTION!

Risk of burning your hands.

If you brake for a long time, a lot of frictional heat is produced at the handrims (especially MaxGrepp and Supergripp).

– Wear suitable gloves.

6.8 Stability and balance when seated

Some everyday activities and actions require you to lean forwards, sideways or backwards out of the wheelchair. This has a major effect on the wheelchair's stability. To keep your balance at all times, proceed as follows:

Leaning forwards



WARNING!

Risk of falling out

If you lean forwards out of the wheelchair you could fall out of it.

- Never bend too far forwards and do not shift forwards in your seat to reach an object.
- Do not bend forwards between your knees to pick up something off the floor.

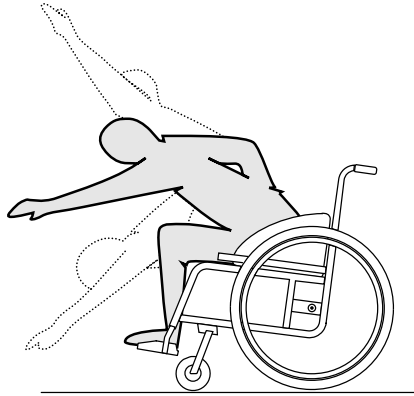

1. Point the front wheels forwards. (To do this, move your wheelchair forwards slightly then back again.)
2. Apply both parking brakes.
3. When leaning forwards your upper body must remain over the front wheels.

Reaching backwards



WARNING!

Risk of falling out

If you lean too far backwards you could tip your wheelchair over.

- Do not lean out over the backrest.
- Use an antitipper device.

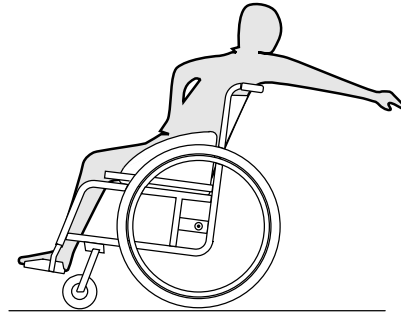

1. Point the front wheels forwards. (To do this, move your wheelchair forwards slightly then back again.)
2. Do not apply the parking brakes.
3. When reaching backwards do not reach so far that you have to change your sitting position.

7 Transport

7.1 Safety information



WARNING!

Risk of injury if the wheelchair is not properly secured

In the event of an accident, braking manoeuvre, etc. you may suffer serious injuries from flying wheelchair parts.

- Always remove the rear wheels when transporting the wheelchair.
- Firmly secure all wheelchair components in the means of transport to prevent them from coming loose during the journey.



IMPORTANT!

Excessive wear and abrasion could affect the strength of load-bearing parts.

- Do not pull your wheelchair across abrasive surfaces without the wheels fitted (e.g. pulling the frame over tarmac).

7.2 Folding and unfolding the wheelchair



IMPORTANT!

- Do not fold and unfold the wheelchair when the back is hinged down.

Folding the wheelchair

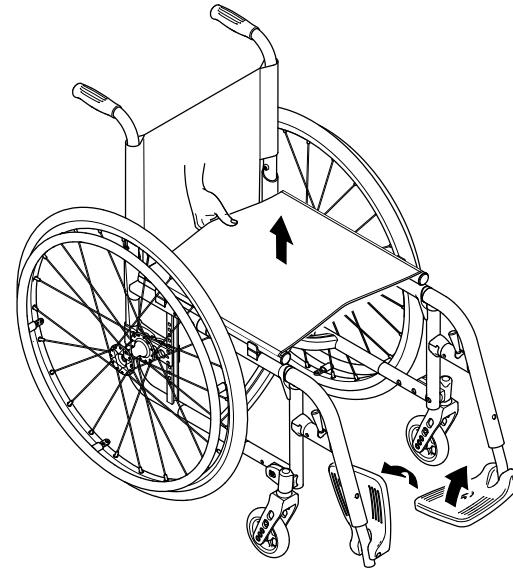

IMPORTANT!

- Release the stabilizing bar, if present, before folding the wheelchair.

1. Remove the seat cushion, if present.
2. Fold the footrests upwards.
3. Pull the seat cover upwards.
4. Now you can fold the backrest down, if your wheelchair is fitted with a folding back.

Unfolding the wheelchair

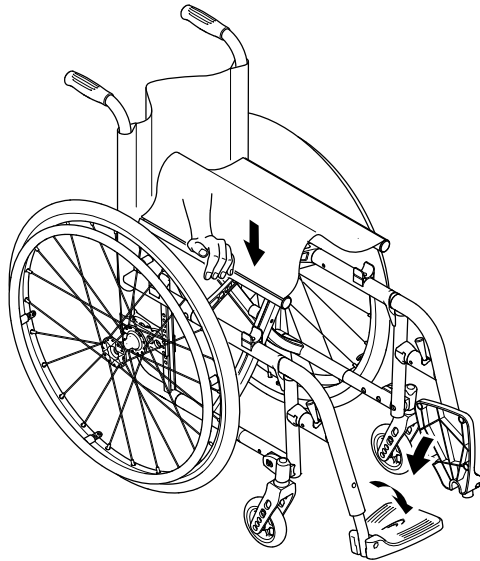

CAUTION!

Risk of getting fingers caught

There is a risk of getting your fingers caught between the seat edge and the frame.

- Never clasp the seat edge with your fingers.

1. Position the wheelchair next to you.
2. If the back is down, fold it up.
3. Tilt the wheelchair, if possible, gently towards you.
4. With your hand flat, press the seat edge closest to you, so that the seat surface flattens out.

5. Put the wheelchair back completely on the floor and check that the seat edges on both sides are in the guide components.
6. Fold the footrests down.

7.3 Removing and fitting the rear wheels



WARNING!

Risk of overturning

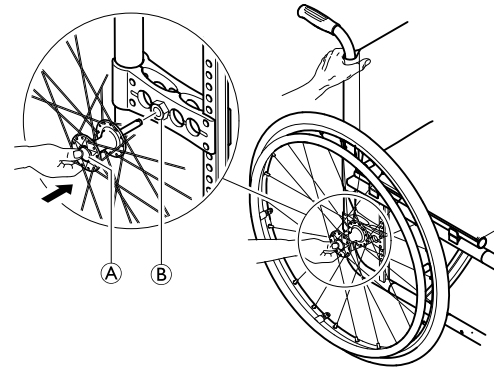

If the removable axle of a rear wheel is not fully engaged, the wheel can become loose during use. This can lead to overturning.

- Always ensure that the removable axles are fully engaged whenever you fit a wheel.



Removing the rear wheels

1. Release the brakes.
2. With one hand, hold the wheelchair upright.

3. With the other, hold the wheel through the external spoke rim around the wheel hub.
4. Using your thumb, press the removable axle button . Keep it pressed and pull the wheel out of the adapter sleeve .

Fitting the rear wheels

1. Release the brakes.
2. With one hand, hold the wheelchair upright.
3. With the other, hold the wheel through the external spoke rim around the wheel hub.
4. Using your thumb, press the removable axle button and hold it down.
5. Push the axle into the adapter sleeve  up to the stop.
6. Release the removable axle button and make sure that the wheel is secure.

7.4 Transporting the occupied wheelchair in a vehicle

Even when the *küschall*[®] Compact or *küschall*[®] Ultra Light wheelchair is properly secured and the following rules are met, injuries to passengers may occur in a collision or sudden stop. Therefore *Küschall* strongly recommends transferring the wheelchair user to the vehicle seat with the seatbelt on. Do not make alterations or substitutions to points of the wheelchair (structure, frame or parts) without the written consent of *Küschall* AG.



WARNING!

Risk of serious injury or death

To use the wheelchair as a seat in a vehicle the backrest height must be at least 400 mm.

To transport the wheelchair with user in a vehicle, a restraint system must be installed in the vehicle.



WARNING!

If, for some reason, it is impossible to transfer the wheelchair user to a vehicle seat, the wheelchair can be used as a seat in a vehicle if the following procedures and regulations are followed.

- The wheelchair must be secured in the vehicle with a 4-point wheelchair restraint system.
- The user must wear a 3-point passenger restraint system secured to the vehicle.
- The user must be additionally secured with a posture belt in the wheelchair.

Both the 4-point wheelchair restraint system and the 3-point passenger restraint system must be approved according to ISO-10542-2.



WARNING!

- Before journey contact transporter and request information about the capability for the below required equipment.
- Make sure there is sufficient free space around the wheelchair and user to avoid the user making contact with other vehicle occupants, unpadded parts of the vehicle, wheelchair accessories or anchor points of the restraint system.



WARNING!

- Make sure the tie-down points at the wheelchair are not damaged and that the parking brakes are fully functional.
- It's recommended to use puncture-proof tyres during transport to avoid brake problems due to reduced tyre pressure.



WARNING!

Injury or damage may occur from wheelchair components or accessories loosened during a collision or sudden stop.

- Ensure all removable or detachable components and accessories are removed from the wheelchair and securely stored in the vehicle.
- It is essential to have your wheelchair checked by a specialist dealer after an accident, collision etc.



WARNING!

- Place the wheelchair with the user forward-facing in direction of vehicle travel.
- Apply the wheelchair parking brakes.
- Activate antitipper (if installed).

The wheelchair tie-down positions where the restraint system straps must be placed are marked with snap hook symbols (see following figures and section 1.2 Symbols, page 5).

1. Using the front and rear straps of the 4-point restraint system, secure the wheelchair to the vehicle mounted rails. Refer to the user manual supplied with 4-point restraint system.



IMPORTANT!

It is recommended that training be given on the proper use of a restraint system product.

- Refer to the user manuals supplied with the restraint systems.
- The following illustrations may differ depending on the restraint system supplier.

Securing the wheelchair with a 4-point restraint system

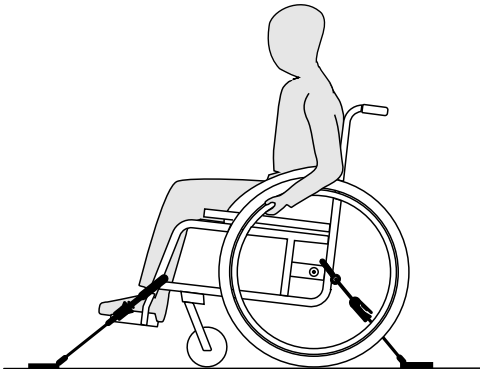

Front side tie-down positions for belt straps

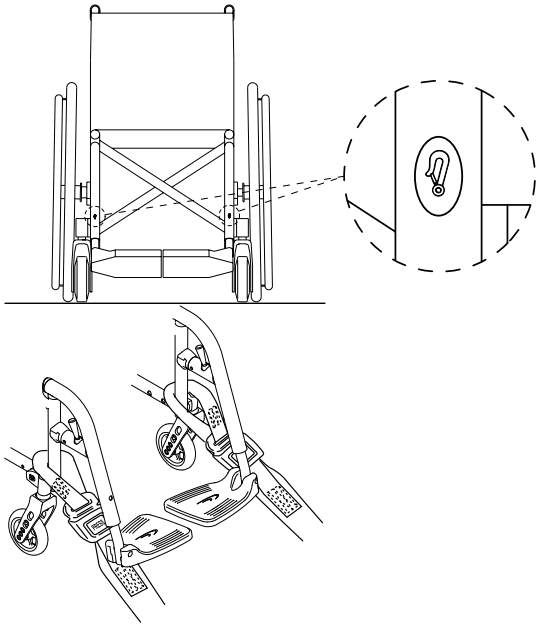

1. Attach the front straps above the castor supporters as shown in the two figures above (see location of the attachment labels).
2. Attach front straps to the rail system referring to best practice recommended instructions from the safety belt manufacturer.
3. Release parking brakes and apply tension front straps by pulling the wheelchair backwards from the rear.
4. Re-apply parking brakes.

Rear side tie-down positions for snap hooks

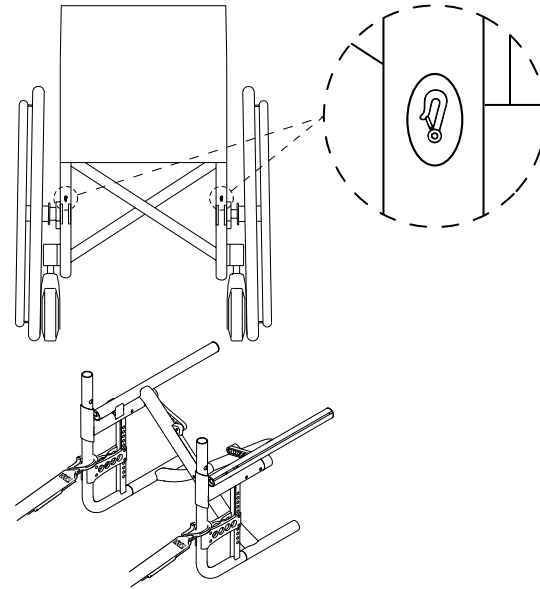

1. Attach the snap hooks to the rear frame right above the adapter plate as shown in the two figures above (see location of the attachment labels).
2. Attach rear straps to the rail system referring to best practice recommended instructions from the safety belt manufacturer.
3. Tighten the straps.



IMPORTANT!

- Make sure that the snap hooks are covered with slip resistant material to avoid laterally slipping on the axle.



IMPORTANT!

- Check the plungers are fully engaged on both sides and located in the same position of the cut-out section of the rail.
- Make sure that the angle between the rails and the straps lies between 40° and 45°.

Fit posture belt



WARNING!

The posture belt must be used in addition to but never as a substitute for an approved passenger restraint system (3-point belt).

1. Adjust posture belt to fit the wheelchair occupant, see section 4.1 Pelvic belt, page 17.

Fastening the 3-point passenger restraint system

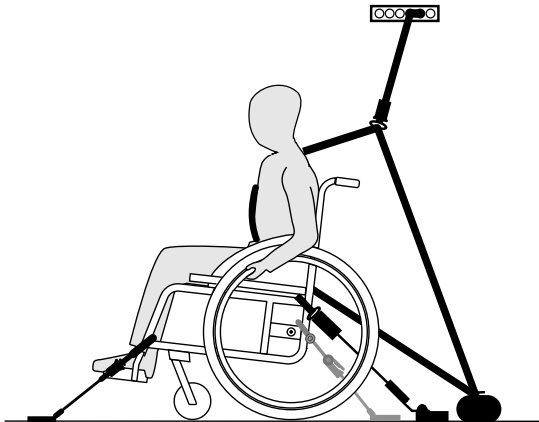

IMPORTANT!

The illustration above may differ depending on the restraint system supplier.



WARNING!

- Ensure the 3-point passenger restraint system fits as tightly across the user's body as possible without discomfort and no part is twisted.
- Ensure the 3-point passenger restraint system is not held away from the user's body by parts of the wheelchair such as armrests or wheels etc.
- Ensure the user restraint has a clear path from the user to the anchor point without interference by any part of the vehicle, wheelchair, seating or accessory.
- Ensure the lap belt fits snugly over the occupant's pelvis and is not allowed to ride up into the abdominal area.
- Ensure the user is able to reach the release mechanism unaided.

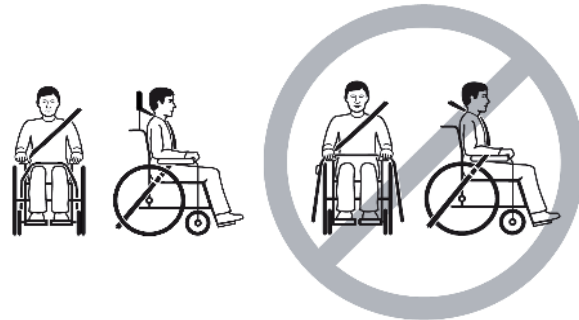

1. Attach the 3-point passenger restraint system referring to the user manual supplied with your 3-point restraint system.

**IMPORTANT!**

- Apply the pelvic belt of the 3-point passenger restraint system low across the pelvis so that the angle of the pelvic belt is within the preferred zone (A) of 30° to 75° to the horizontal. A steeper angle is preferred, but never exceeding 75°.

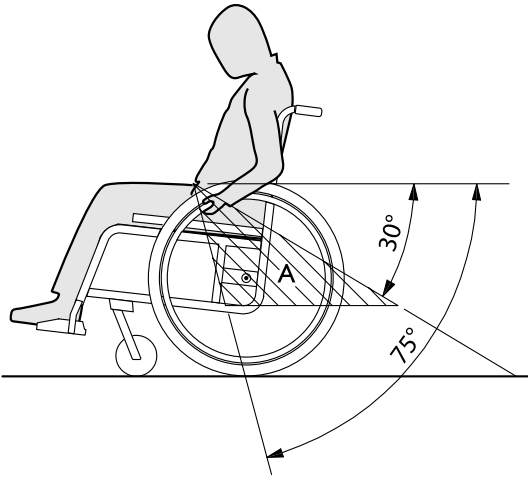

8 Maintenance

8.1 Safety information



WARNING!

Some materials deteriorate naturally over time. This could result in damage to wheelchair components.

- Your wheelchair should be checked by a specialist dealer at least once a year or if it has not been used for a long period.



Your *küschall*® specialist dealer can provide help in carrying out regular maintenance. To find an authorised specialist dealer near you, contact the *küschall*® distributor for your country (end of this document).

8.2 Maintenance Schedule

To ensure safe and reliable operation, carry out the following checks and maintenance regularly or have it carried out by another person.

	weekly	monthly	annually
Check the tyre pressure	x		
Check that rear wheels are seated correctly	x		
Check pelvic belt	x		
Visual check		x	
Clean the front wheels		x	
Check bolts		x	
Check spokes		x	

	weekly	monthly	annually
Check parking brakes		x	
Have wheelchair checked by a specialist dealer			x

Check the tyre pressure

1. Check the tyre pressure, 11.3 Tyres, page 43.
2. Inflate the tyres to the required pressure.
3. Check the tyre tread at the same time.
4. If necessary, change the tyres.

Check that rear wheels are seated correctly

1. Pull on the rear wheel to check that the removable axle is seated correctly. The wheel should not come off.
2. If the rear wheels are not engaged properly, remove any dirt or deposits. If the problem persists, have the removable axles re-fitted by a specialist dealer.

Check pelvic belt

1. Check that the pelvic belt is adjusted correctly.



IMPORTANT!

- Loose pelvic belts must be adjusted by a specialist dealer.
- Damaged pelvic belts must be replaced by a specialist dealer.

Visual check

1. Examine your wheelchair for loose parts, cracks or other defects.
2. If you find anything, have your wheelchair checked immediately by a specialist dealer.

Clean the front wheels

1. Check that the front wheels turn freely.
2. Remove any dirt or hair from the front wheel bearings.

Check the bolts

Bolts can work loose through constant use.

1. Check that the bolts are tight (on the footrest, seat cover, sides, backrest, frame, seat module).
2. Tighten any loose bolts with the suitable torque. Therefore refer to the Service Manual *küschall Compact*, available on the internet at www.kueschall.com.



IMPORTANT!

Safety nuts and bolts lose their effectiveness as a result of repeated loosening and tightening.
– Safety nuts and bolts must be replaced by a specialist dealer.

Check the spoke tension

The spokes should not be loose or distorted.

1. Loose spokes must be tightened by a specialist dealer.
2. Broken spokes must be replaced by a specialist dealer.

Check the parking brakes

1. Check that the parking brakes are positioned correctly. The brake is set correctly if the brake shoe depresses the tyre by a few millimetres when the brake is applied.
2. If you find that the setting is not correct, have the brakes correctly set by a specialist dealer.



IMPORTANT!

The parking brakes must be reset after replacing the rear wheels or changing their position.

Checking after a heavy collision or blow



IMPORTANT!

The wheelchair can sustain visibly undetectable damage as a result of a heavy collision or hard blow.
– It is essential to have your wheelchair checked by a specialist dealer after a heavy collision or hard blow.

Repairing or changing an inner tube

1. Remove the rear wheel and release any air from the inner tube.
2. Lift one tyre wall away from the rim using a bicycle tyre lever. Do not use sharp objects such as a screwdriver which could damage the inner tube.
3. Pull the inner tube out of the tyre.
4. Repair the inner tube using a bicycle repair kit or, if necessary, replace the tube.
5. Inflate the tube slightly until it becomes round.
6. Insert the valve into the valve hole on the rim and place the tube inside the tyre (the tube should lie right round the tyre with no creases).
7. Lift the tyre wall over the edge of the rim. Start close to the valve and use a bicycle tyre lever. When doing this, check all the way round to ensure that the inner tube is not trapped between the tyre and the rim.
8. Inflate the tyre to the maximum operating pressure. Check that no air is escaping from the tyre.

Spare parts



All spare parts may be obtained from a *küschall*® specialist dealer. A current list of spare parts is available on the internet at www.kueschall.com.

8.3 Cleaning

Your wheelchair will serve you well for many years if you clean it regularly.



IMPORTANT!

Sand and seawater can damage the bearings and steel parts can rust if the surface is damaged.

- Only expose the wheelchair to sand and seawater for short periods and clean it after every trip to the beach.



IMPORTANT!

- Do not use coarse abrasives, aggressive cleaning products or high-pressure cleaners.

1. Clean the cushions and metal parts with a soft, damp cloth.
2. Dry the wheelchair carefully with a cloth after using it in the rain or in the shower.
3. If the wheelchair is dirty, wipe off the dirt as soon as possible with a damp cloth and dry it carefully.

8.4 Disinfection

The wheelchair may be disinfected by spraying or wiping with tested, approved disinfectants.



The Robert Koch Institute has a list of currently approved disinfectants at www.rki.de.

9 Troubleshooting

9.1 Safety information

Faults may arise as a result of daily use, adjustments or changing demands on the wheelchair. The table below shows how to identify and repair faults.

**CAUTION!**

- Contact your specialist dealer immediately if you notice a fault with your wheelchair, e.g. a significant change in handling.

**IMPORTANT!**

- Some of the actions listed must be carried out by an authorised specialist dealer. These are indicated. We recommend that *all* adjustments are carried out by a specialist dealer.

9.2 Identifying and repairing faults

Fault	Possible cause	Action
The wheelchair does not travel in a straight line	Incorrect tyre pressure on one rear wheel	Correct tyre pressure, → 11.3 Tyres, page 43
	One or more spokes broken	Replace faulty spoke(s), → specialist dealer
	Spokes tightened unevenly	Tighten loose spokes, → specialist dealer
	Front wheel bearings are dirty or damaged	Clean or replace the bearings, → specialist dealer
The wheelchair tips backwards too easily	Rear wheels are mounted too far forwards	Mount the rear wheels further back, → specialist dealer
	Back angle too large	Reduce the backrest angle, → specialist dealer
	Seat angle too large	Mount the adapter plate lower on the side profile, → specialist dealer Select a smaller front fork, → specialist dealer
The brakes are gripping poorly or asymmetrically	Incorrect tyre pressure in one or both rear tyres	Correct tyre pressure, → 11.3 Tyres, page 43
	Brake setting incorrect	Correct the brake setting, → specialist dealer
Rolling resistance is very high	Tyre pressure in rear tyres is too low	Correct tyre pressure, → 11.3 Tyres, page 43
	Rear wheels not parallel	Ensure the rear wheels are parallel, → specialist dealer
The front wheels wobble when moving fast	Too little tension in front wheel bearing block	Tighten the nut on the bearing block axle slightly, → specialist dealer
	Front wheel has worn smooth	Change front wheel, → specialist dealer
The front wheel is stiff or stuck	Bearings are dirty or faulty	Clean or replace the bearings, → specialist dealer
The wheelchair is very difficult to unfold	Backrest cover is too tight	Loosen the Velcro bands of the backrest cover a little, → 3.3 Backrest, page 10

10 After Use

10.1 Re-use

The wheelchair is suitable for re-use. The following actions should be taken:

- Cleaning and disinfection, 8.3 Cleaning, page 38 and 8.4 Disinfection, page 38 in this manual.
- Inspection, 8.2 Maintenance Schedule, page 36 in this manual.
- The wheelchair should be adapted for the new user in accordance with the service documentation (available from the *küschall*[®] distributor in your country).

10.2 Disposal

Be environmentally aware and dispose of your wheelchair properly. Disposal is subject to national and local regulations.

-  For correct disposal, contact your specialist dealer or ask your town or district council about local waste management companies.

11 Technical data

11.1 Dimensions and weight

All dimension and weight specifications refer to a seat width of 400 mm, seat depth of 400 mm in the lightest configuration of the wheelchair. Dimension and weight may alter according to different configurations.

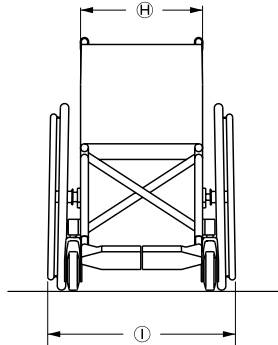
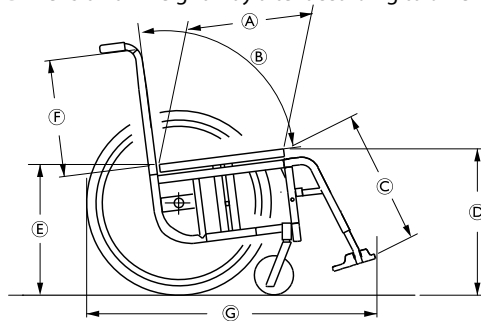

Ⓐ	Seat depth	320 - 500 mm, in increments of 20 mm
Ⓑ	Backrest angle	82°, 86°, 90°, 94°, 98°, 102°
Ⓒ	Knee-to-heel length	210 - 510 mm
Ⓓ	Seat height front	380 - 530 mm, in increments of 10 mm
Ⓔ	Seat height rear	380 - 500 mm, in increments of 10 mm
Ⓕ	Backrest height	300 - 510 mm, in increments of 15 mm
Ⓖ	Total length	70°: approx. 940 mm 80°: approx. 890 mm 90°: approx. 840 mm
Ⓗ	Seat width	280 - 500 mm, in increments of 20 mm
Ⓘ	Total width	Seat width + 180 mm
	Total width, folded	approx. 290 mm
	Weight	approx. 11 kg
	Transport weight (without rear wheels)	approx. 8.3 kg
	Maximum user weight	130 kg
	Reversing width	920 - 1230 mm

11.2 Environmental conditions

Do not expose the wheelchair to temperatures below -20 °C or above 40 °C.



11.3 Tyres

The ideal pressure depends on the tyre type:

Tyre	Max. pressure		
	bar	kPa	psi
Low-resistance tyre	7 bar	700 kPa	101 psi
Treaded tyre (marathon)	7.5 bar	750 kPa	108 psi
Slick tyres (speed run)	10 bar	1000 kPa	145 psi
Mountain bike tyre	4 bar	400 kPa	58 psi
Solid rubber tyre	-	-	-

11.4 Identification label

The identification label is attached to the frame of your wheelchair and gives the following information:

A Küschall AG
 Benkenstrasse 260
 4108 Witterswil
 SWITZERLAND
B KÜSCHALL Compact 2009 SB 400 mm
C  07/09/2012 i Read User Manual
E  130 kg ⊘
G SN 01234567890
H  Active wheelchair, tipping possible !

A	Manufacturer's address
B	Product description
C	Date of manufacture
D	Instruction to read the User Manual
E	Maximum user weight
F	Instruction that this wheelchair is not designed for passenger transport in vehicles with a backrest height less than 400 mm. If the backrest height is more than 400 mm passenger transport in vehicles is allowed under following conditions, → 7.4 Transporting the occupied wheelchair in a vehicle, page 31. In this case symbol  is not struck out on the identification label.
G	Serial number
H	Warning that this is an active wheelchair and can tip

Küschall® distributors

United Kingdom:

Invacare Limited,
Pencoed Technology Park, Pencoed, Bridgend CF35 5AQ,
Switchboard
Tel: (44) (0)1656 776 200, Fax: (44) (0)1656 776 201,
Customer services
Tel: (44) (0) 1656 776 222, Fax: (44) (0) 1656 776 220
uk@invacare.com

Ireland:

Invacare Ireland Ltd,
Unit 5 Seatown Business Campus, Seatown Road, Swords,
County Dublin
Tel : (353) 1 810 7084, Fax: (353) 1 810 7085
ireland@invacare.com

Australia:

Invacare Australia Pty Ltd,
ABN 45 074 676 378, PO Box 5002, 1 Lenton Place,
North Rocks, NSW 2151, Australia
Freephone: 1800 069 042, Fax: 02 8839 5353,
E-mail: sales@invacare.com.au
Web: www.invacare.com.au

New Zealand:

Invacare New Zealand,
PO Box 62-124, 4 Westfield Place, Mt. Wellington
Auckland, New Zealand
Freephone: 8000 468 222, Freefax: 0800 807 788,
E-mail: sales@invacare.co.nz
Web: www.invacare.co.nz

Asia:

Invacare Asia Ltd.,
PO Box 5002, 1 Lenton Place,
North Rocks, NSW 2151, Australia
Phone: +61 2 8839 5330, Fax: +61 2 8839 5331
E-mail: asiasales@invacare.com
Web: www.invacare.com



Küschall AG,
Benkenstrasse 260,
CH-4108 Witterswil,
www.kuschall.com

1530387-B 2013-09-04



 **küschall**®
designed for life